



گروه دريچه سازي کيميا صنعت

WWW.KIMIASANAAT.IR

توليد کننده انواع دريچه هاي
تنظيم هوا و دمپر هاي صنعتي



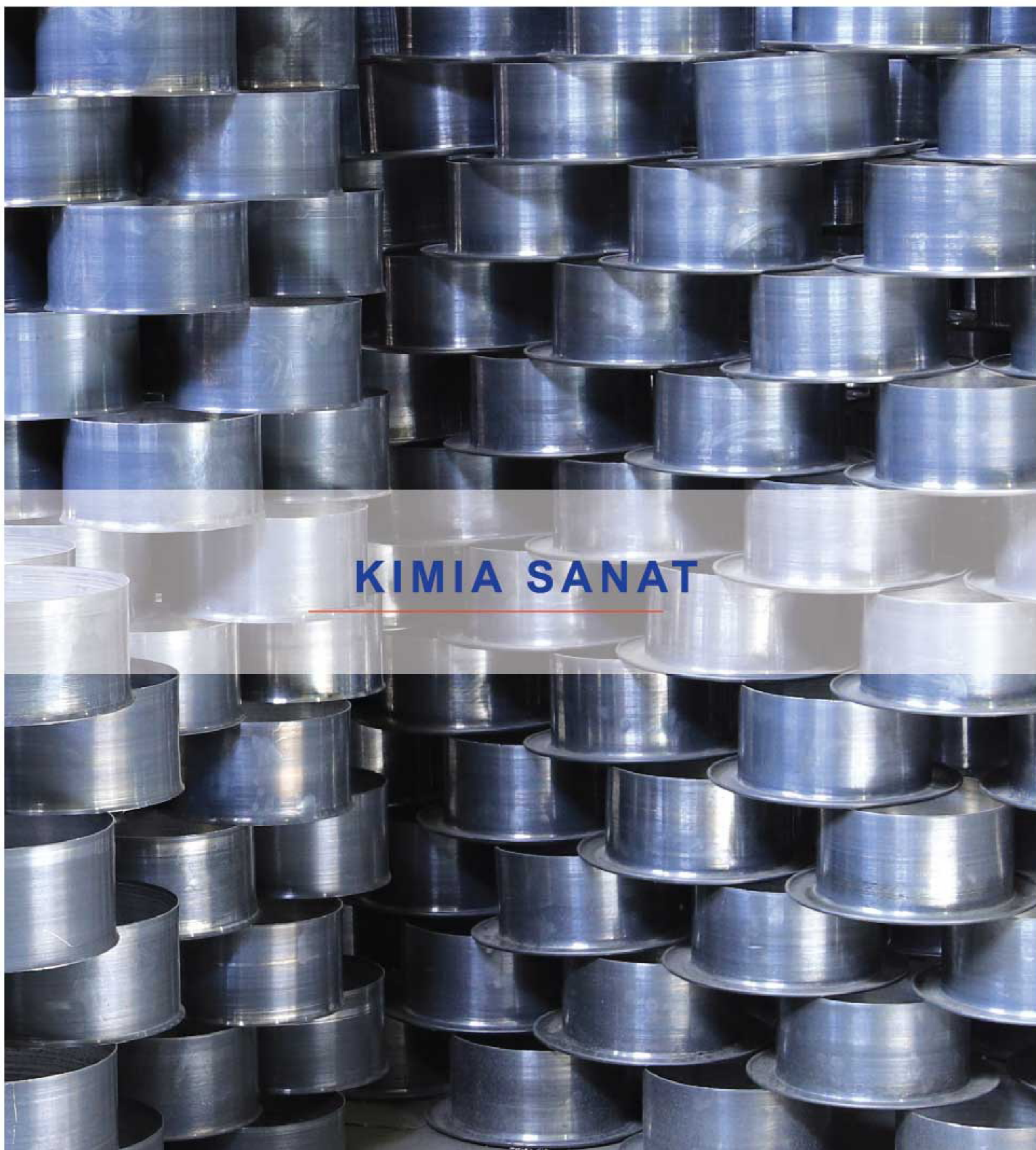

Introduction

Kimia Sanat Industrial Group in order to produce all types of air adjustments and industrial dampers are established in 2000. This company with a purpose of new design, diverse productions and employing experienced engineers has tried to meet customer's need in this field.

The second factory with the purpose of producing all kinds of Aluminum and industrial dampers was built on a 5000 square-meter site in the Sejzi industrial zone in 2012.

The third factory in a space of over 2000 square-meter to produce all kinds of plastic grilles, air conditioning systems in Sejzi industrial area was launched in 2018.

























Today after passing many years of company's activity, according to strong belief in the customer orientation and achieve high quality and quantitative goals in production of ventilation grilles, air regulation and industrial dampers offers the variety of products with the best materials.

At present, this company has been able to gain a major market by relying on the technical knowledge of its managers and staff, and also create job opportunity for more than 60 people in production and service unit.

The activity of Kimia Sanat industrial Group includes the various types of air conditioning grilles, industrial dampers; establishment and implementation of air conditioning ducts, sale of elastomeric insulation and flexible pipes. All products of this group are based on the priority in product quality according to European CE standards and quality control system ISO9001 / ISO10002.

This industrial complex has been able to take effective steps to self-sufficiency by utilizing the power and knowledge of human resources significantly cover the needs of various industries, powerhouses, oil, gas and petrochemical projects, clinics, hospitals, universities, metro stations, etc.

Contents

23	Armstrong Diffusers		13	Fan Coil Channel Door Grilles		4	Double Deflection Grilles	
24	Damper Behind the Grilles & Registers		14	Access Door		5	Door Louber	
25	Roof-top Fresh & Exhaust Louver		15	Jet Diffuser		6	Ventilation Grilles	
25	Intake Louver		16	Jet Nozzle Diffuser		7	Linear Slot Diffusers	
26	Volume Control Dampers		17	Round Diffusers		7	Pnum Box	
27	Damper Double Skin Shape		19	Disc Valve		10	Linear Bar Grilles	
29	Fire Dampers		20	Egg Crate Grilles		11	Surgery Room Supply Grille	
30	Aluminium Volume Control Damper		22	Square Ceiling Diffuser Wide		12	Swirl Diffusers	
30	Balance Dampers							

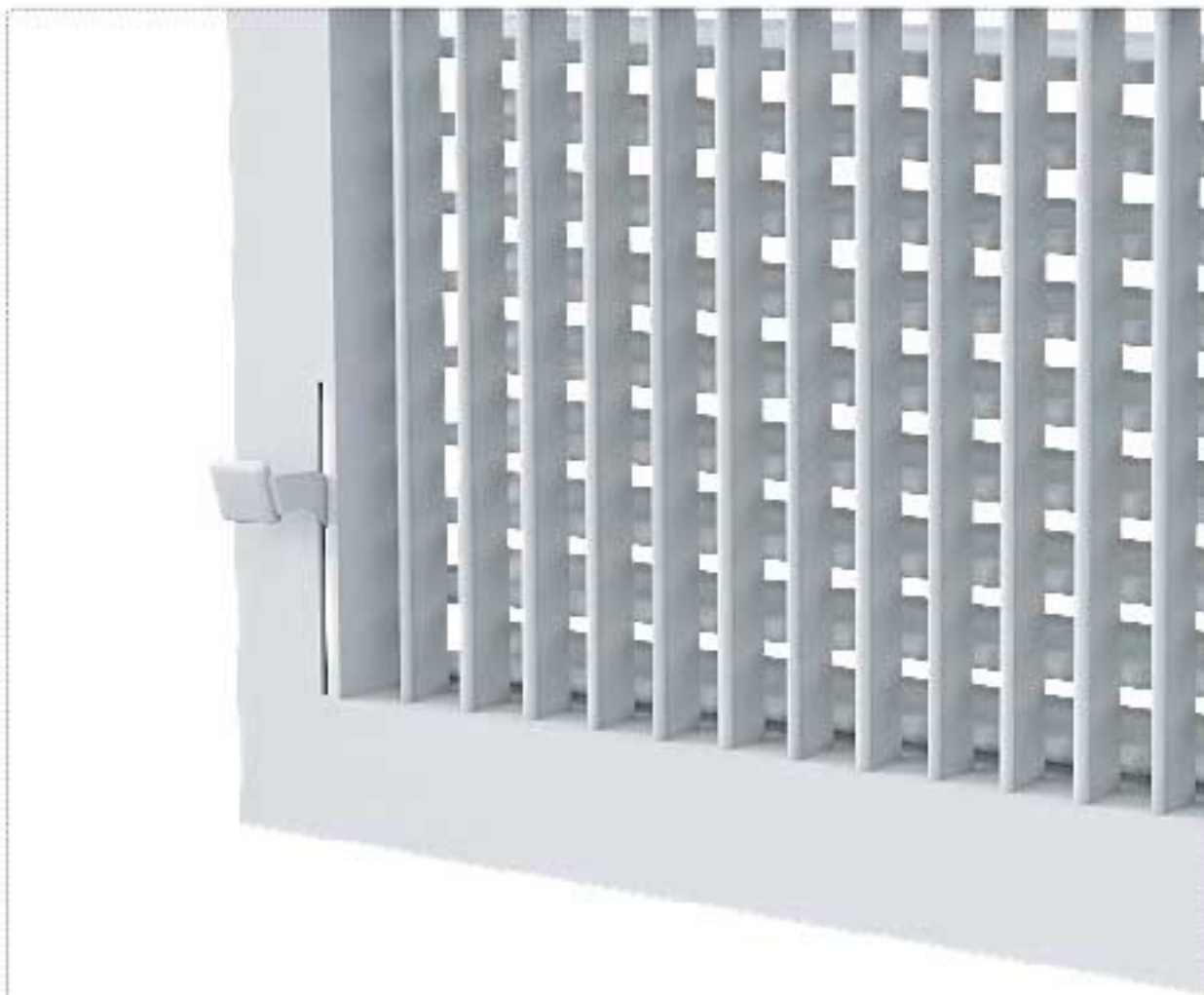

Material:

This grills are made of Iron, Aluminum and Plastics.

Capabilities:

- Capable of installation on the wall to set the direction of Debi and orient the outlet air from the grilles in 4 directions
- Long throw length (throughout the room)
- Ability to orient air flow with movable blades
- Aeration speed up to 2000 foot per minute

Application:

- The main consumption of this model is on the channels branching from the cooler so it is called the Grille.



Supply Air Grilles & Registers

Size Selection Chart 50-500 CFM - Supply Grille 2 Deflection

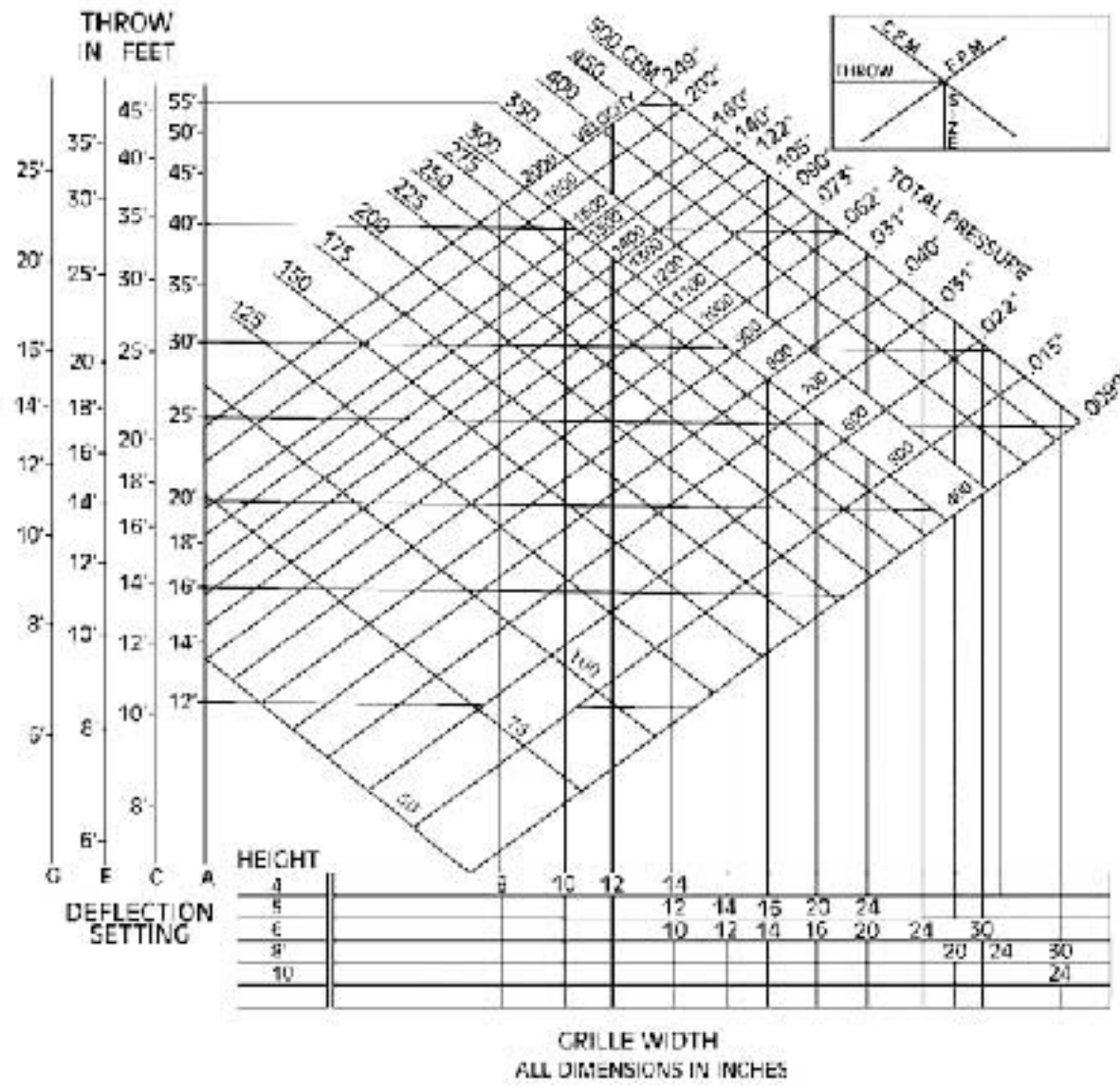

Size (inches)	CFM (range)	Size (inches)	CFM (range)	Size (inches)	CFM (range)	Size (inches)	CFM (range)
8 x 4	50-150	10 x 6	100-200	30 x 6	300-800	20 x 8	200-500
10 x 4	50-200	12 x 6	100-250	32 x 6	300-800	24 x 8	300-800
14 x 4	100-200	16 x 6	100-250	36 x 6	400-800	28 x 8	400-800
18 x 4	100-250	18 x 6	100-250	10 x 8	100-250	30 x 8	500-800
20 x 4	100-250	20 x 6	100-300	12 x 8	100-250	32 x 8	500-800
24 x 4	100-250	24 x 6	150-400	16 x 8	150-300	36 x 8	500-1000
8 x 6	50-200	28 x 6	200-500	18 x 8	150-400	12 x 10	100-300

Size (inches)	CFM (range)	Size (inches)	CFM (range)	Size (inches)	CFM (range)	Size (inches)	CFM (range)
14 x 10	150-400	32 x 10	500-1200	24 x 12	500-1000	18 x 14	500-800
16 x 10	200-500	36 x 10	500-1300	28 x 12	500-1200	24 x 14	500-1200
18 x 10	300-800	12 x 12	150-400	30 x 12	500-1300	30 x 14	800-1400
20 x 10	300-800	14 x 12	200-500	32 x 12	500-1300	16 x 16	500-800
24 x 10	500-800	16 x 12	300-800	36 x 12	500-1400	20 x 16	500-1200
28 x 10	500-1000	18 x 12	400-800	14 x 14	300-800	24 x 16	500-1300
30 x 10	500-1000	20 x 12	500-800	16 x 14	400-800	30 x 16	800-1400



Size Selection Chart 500-3500 CFM - Supply Grille 2 Deflection

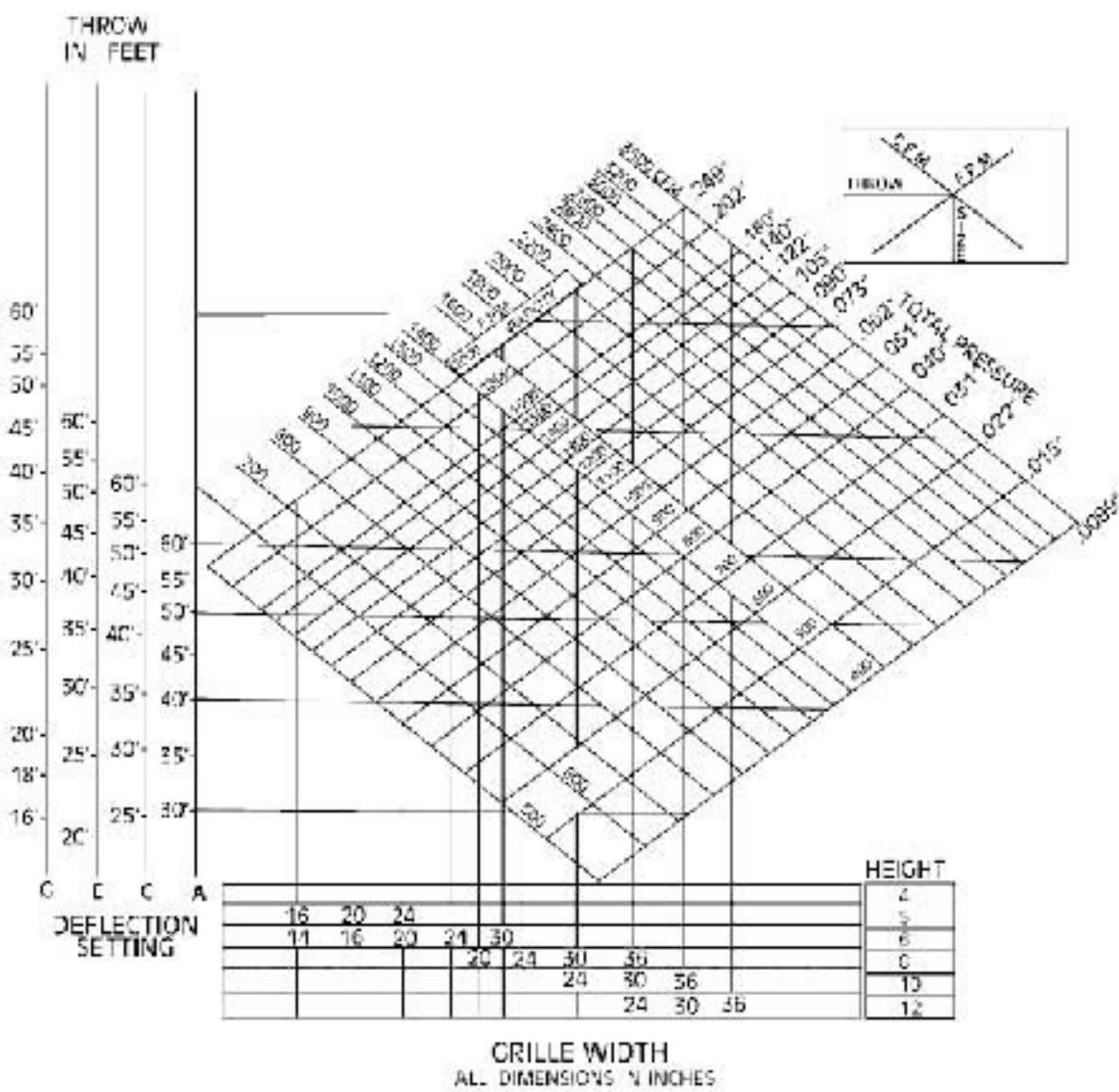

دریچه دیواری با دمپر جدید اهرمی

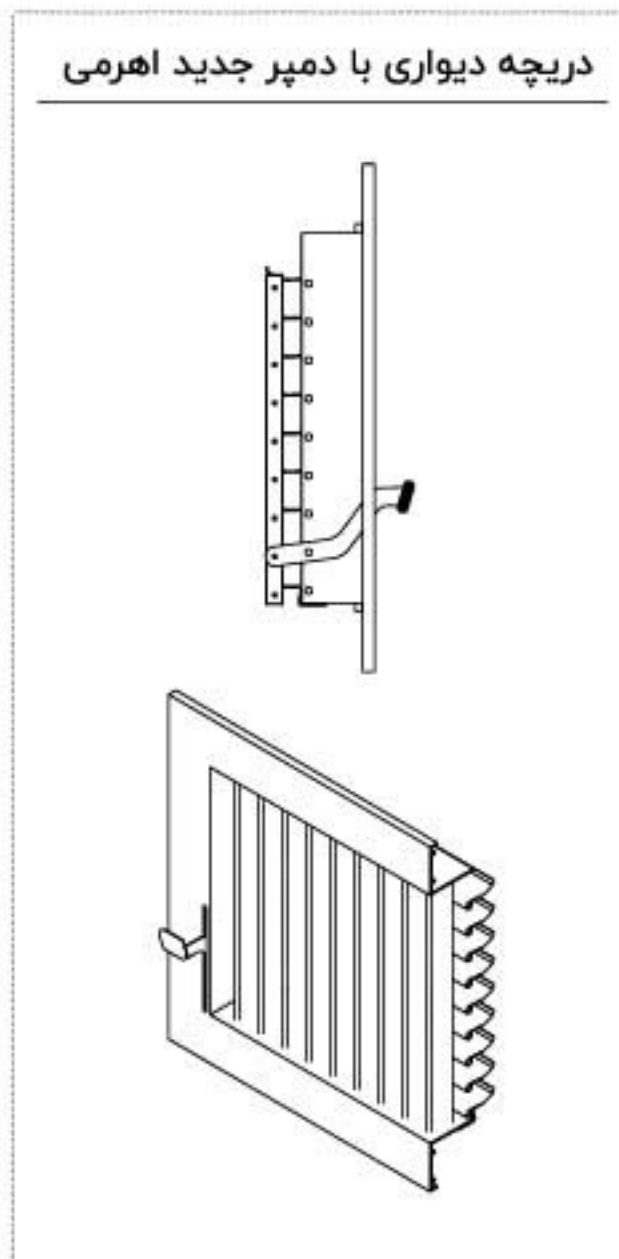

دریچه دیواری پشت بلند ولومی

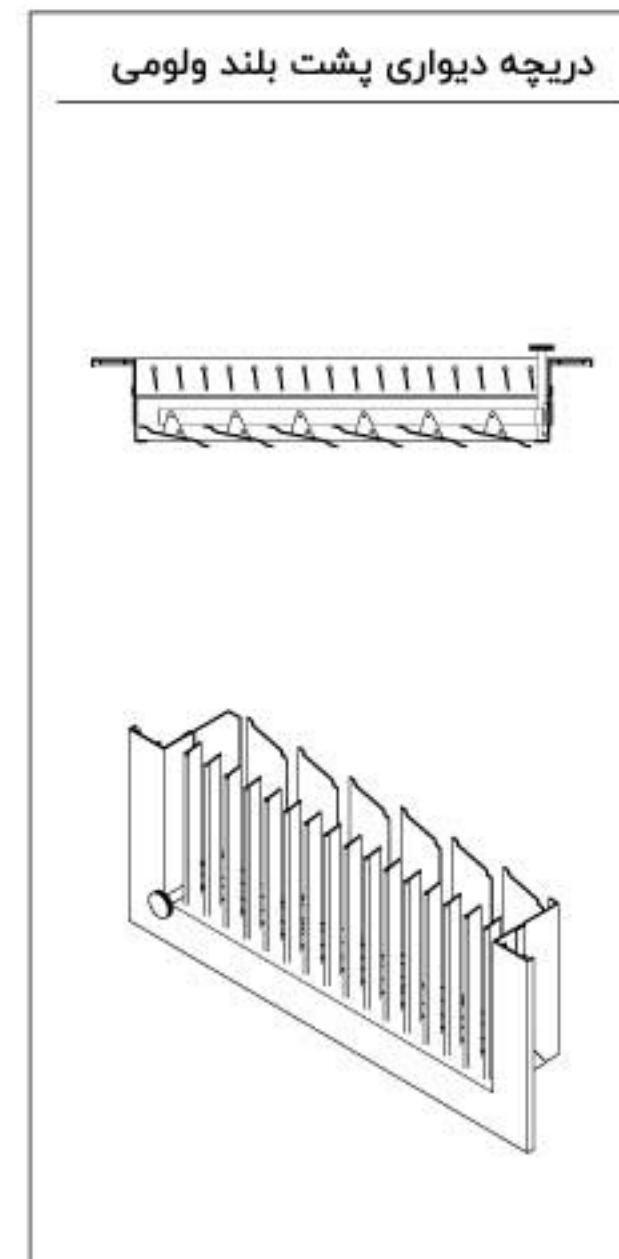

دریچه دیواری پلاستیکی با پوشش زمستانه

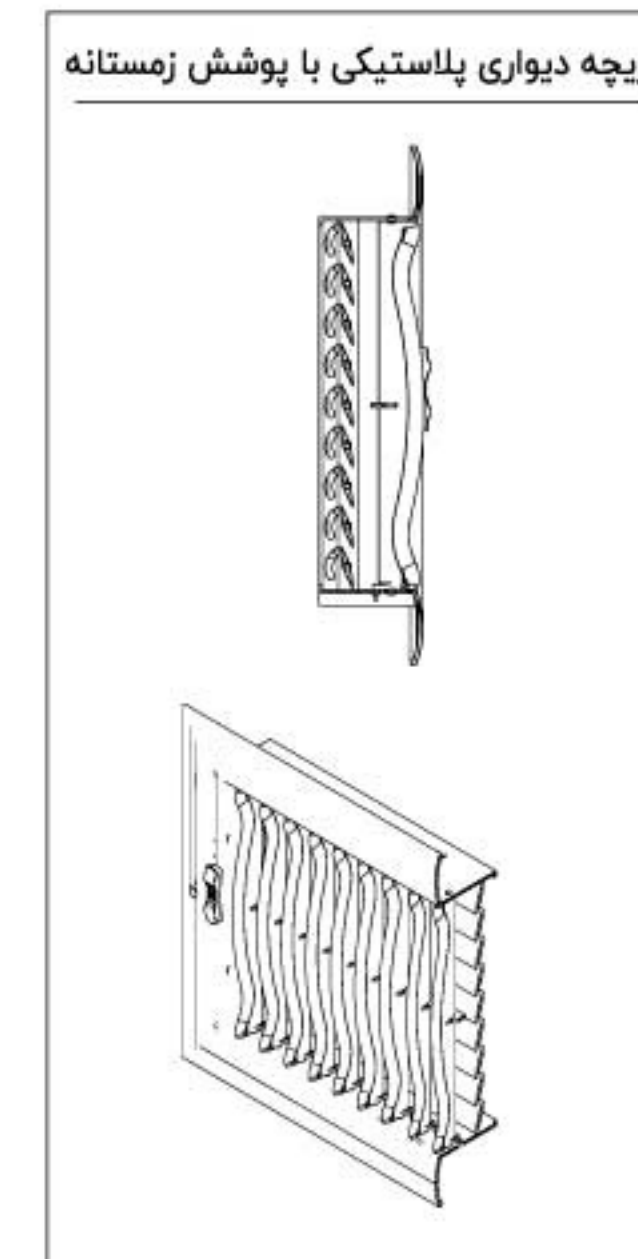

Size (inch)	Anem Area Sq.Ft	ANEMOMETER VELOCITIES							
		200 FPM	300 FPM	400 FPM	500 FPM	600 FPM	700 FPM	800 FPM	900 FPM
12x6	0.270	55	80	110	135	160	190	215	245
18x6	0.440	90	130	175	220	265	310	350	395
24x6	0.630	125	190	250	315	380	440	505	565
12x8	0.373	75	110	150	185	225	260	300	335
18x8	0.630	125	190	250	315	380	440	505	565
24x8	0.870	175	260	350	435	520	610	695	785
12x10	0.520	105	155	210	260	310	365	415	470
18x10	0.820	165	245	330	410	490	575	655	740
24x10	1.120	225	335	450	560	670	785	895	1010
30x10	1.420	285	425	570	710	850	995	1135	1280
12x12	630	125	190	250	315	380	440	505	565
18x12	985	195	295	395	490	590	690	790	885
24x12	1.370	275	410	550	685	820	960	1095	1235
30x12	1.750	350	525	700	875	1050	1225	1400	1575
36x12	2.100	420	630	840	1050	1260	1470	1680	1890
18x16	1.370	275	410	550	685	820	960	1095	1235
24x16	1.860	370	560	745	930	1115	1300	1490	1675
30x16	2.340	470	700	935	1170	1405	1640	1870	2105
36x16	2.840	570	850	1135	1420	1705	1990	2270	2555
24x20	2.340	470	700	935	1170	1405	1640	1870	2105
30x20	2.950	590	885	1180	1475	1770	2065	2360	2655
36x20	3.570	715	1070	1430	1785	2140	2500	2855	3215
42x20	4.220	845	1265	1690	2110	2530	2955	3375	3800
48x20	4.830	965	1450	1930	2415	2900	3380	3865	4345
24x24	2.840	570	850	1135	1420	1705	1990	2270	2555
30x24	3.570	715	1070	1430	1785	2140	2500	2855	3215
36x24	4.320	865	1295	1730	2160	2590	3025	3455	3890
42x24	5.100	1020	1530	2040	2550	3060	3570	4080	4590
48x24	5.840	1170	1750	2335	2920	3505	4090	4670	5255
36x36	6.580	1315	1975	2630	3290	3950	4605	5265	5920
42x36	7.340	1470	2200	2935	3670	4405	5140	5870	6605
48x36	8.750	1750	2625	3500	4375	5250	6125	7000	7875
Static press Differential Across Grille In Inches W.G		0.25	0.40	.072	.108	.159	.221	.283	.359



Door Louver

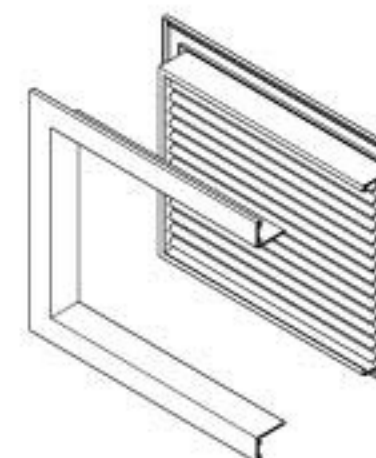
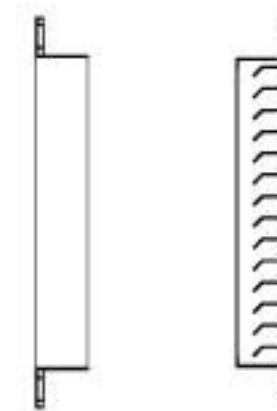
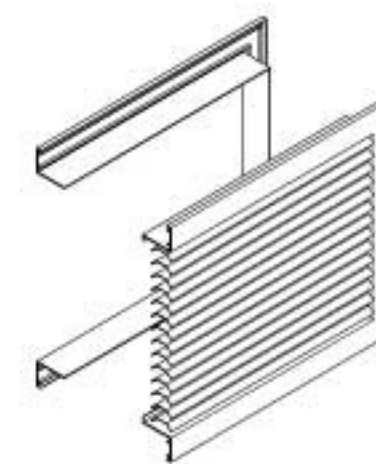

Application

- Circulation fresh air in different zones in Air Conditioning System without need to canalize for return air
- Ability to install on the doors of each zone

Capabilities:

- Low drop duo to the shape of the blades
- Ability to build by Aluminum material
- Ventilation and air circulation on both sides of the Grille
- Connection two frames in bilateral fitting
- Includes two frames to adjust the depth from 3 to 5 cm to match the view of the grille
- Lack of view on both sides of the Grille due to the shape of the blades

Size (inch)	Anem. Effective Area sq.ft.	AIR CAPACITIES IN CFM							
		300 FPM	400 FPM	500 FPM	600 FPM	700 FPM	800 FPM	900 FPM	1000 FPM
10X6	0.246	74	99	123	148	172	197	222	246
12X6	0.30	90	120	150	180	210	240	270	300
10X8	0.336	101	135	168	202	235	269	302	336
12X8	0.418	126	168	209	251	293	335	376	418
18X6	0.464	139	186	232	279	325	371	418	464
12X12	0.655	196	262	327	393	458	523	590	655
18X12	0.991	298	396	495	594	694	793	892	991
24X12	1.36	408	544	680	815	952	1090	1225	1360
18X18	1.56	468	625	780	935	1092	1250	1403	1560
30X12	1.70	510	680	850	1020	1190	1360	1530	1700
24X18	2.08	624	832	1040	1248	1547	1665	1872	2080
30X18	2.62	786	1050	1310	1573	1834	2098	2357	2620
24X24	2.81	843	1125	1405	1685	1970	2245	2530	2810
36X18	3.18	954	1272	1590	1910	2230	2542	2860	3180
30X24	3.54	1062	1417	1770	2125	2480	2830	3185	3540
36X24	4.28	1285	1715	2142	2570	3000	3430	3860	4280
36X30	5.42	1625	2170	2710	3250	3790	4330	4870	5420
48X24	5.72	1715	2290	2860	3430	4000	4570	5150	5720
48X30	7.34	2200	2935	3670	4400	5140	5870	6610	7340
48X36	8.71	2610	3485	4360	5220	6090	6970	7840	8710
		Negative Static Pressure (IN . H2O)							
.75 Bar Spacing		0.022	0.039	0.059	0.084	0.112	0.148	0.187	0.225



Ventilation Grille

Material:

Iron plate

Capabilities:

Fresh air circulation in different zones in Air Conditioning System without need to canalize for return air

Application:

Installation on door and wall

Plastic Ventilation Grille

Material:

Plastic

Capabilities:

Fresh air circulation in different zones in Air Conditioning System without canalizing for return air

Application:

Installation on door and wall

Front View Grilles

Material:

Aluminum Plate

Capabilities:

Fresh air circulation in different zones in Air Conditioning system without canalizing for return air

Application:

Installation on door and wall

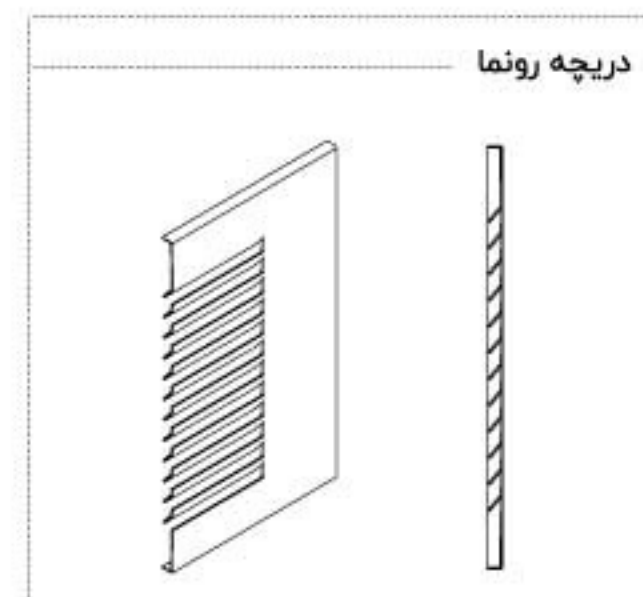
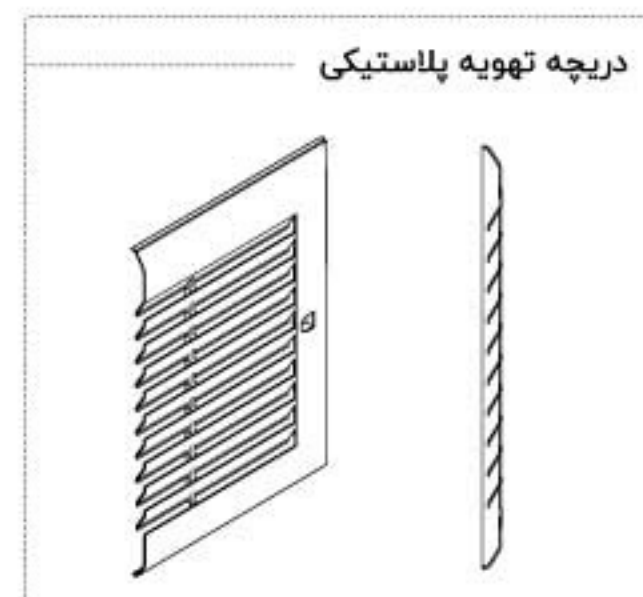
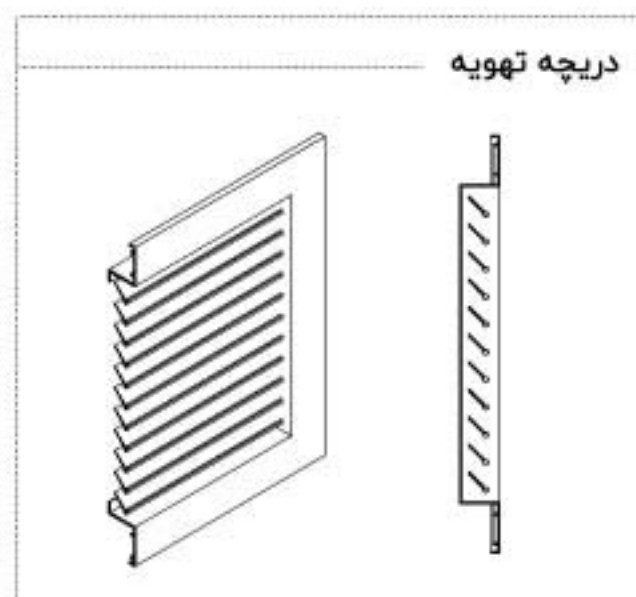

CFM per linear foot	1 slot		2 slot		3 slot	
	Face velocity FPM	Throw in feet	Face velocity FPM	Throw in feet	Face velocity FPM	Throw in feet
40	600	6.9	*****	*****	*****	*****
50	750	8.2	375	5.2	*****	*****
60	900	9.8	450	7.2	300	5.5
80	1200	11.8	600	10.1	400	8.2
100	1500	13.4	750	12.1	500	10.1
120	1800	15	900	14.1	600	12.1
140	2100	16	1050	15.4	700	13.4
160	2400	17.7	1200	16.7	800	15.4
180	2700	18.7	1350	18	900	17
200	3000	19.7	1500	19	1000	18.3
300	4500	23.6	2250	23	1500	22.6

Selection Table For Liner Slot Diffusers 1-3

CFM per linear foot	4 slot		5 slot		6 slot	
	Face velocity FPM	Throw in feet	Face velocity FPM	Throw in feet	Face velocity FPM	Throw in feet
80	300	5.5	*****	*****	*****	*****
100	375	8.5	300	6.8	*****	*****
120	450	10.5	360	9.1	300	5.9
140	525	11.8	420	10.8	350	7.5
160	600	13	480	12.1	400	9.1
180	675	15	540	13.4	450	10.8
200	750	17.2	600	15	500	12.4
300	1125	22	900	21	750	14.1

Selection Table For Liner Slot Diffusers 4-6

COLLAR SIZE (DIA)	1. slot				2. slot				3. slot				4. slot			
	H	A	B	C	H	A	B	C	H	A	B	C	H	A	B	C
4"	5"	4.3"	2.3"	2.2"	5"	5.9"	3.9"	2.2"								
5"	6"	4.3"	2.3"	2.2"	6"	5.9"	3.9"	2.2"								
6"	7"	4.3"	2.3"	2.2"	7"	5.9"	3.9"	2.2"	7"	7.4"	5.5"	2.2"	9"	9"	7"	2.2"
7"					9"	5.9"	3.9"	2.2"	9"	7.4"	5.5"	2.2"	9"	9"	7"	2.2"
8"					11"	5.9"	3.9"	2.2"	11"	7.4"	5.5"	2.2"	11"	9"	7"	2.2"
9"									13"	7.4"	5.5"	2.2"	13"	9"	7"	2.2"

Selection Table For Plenum Box

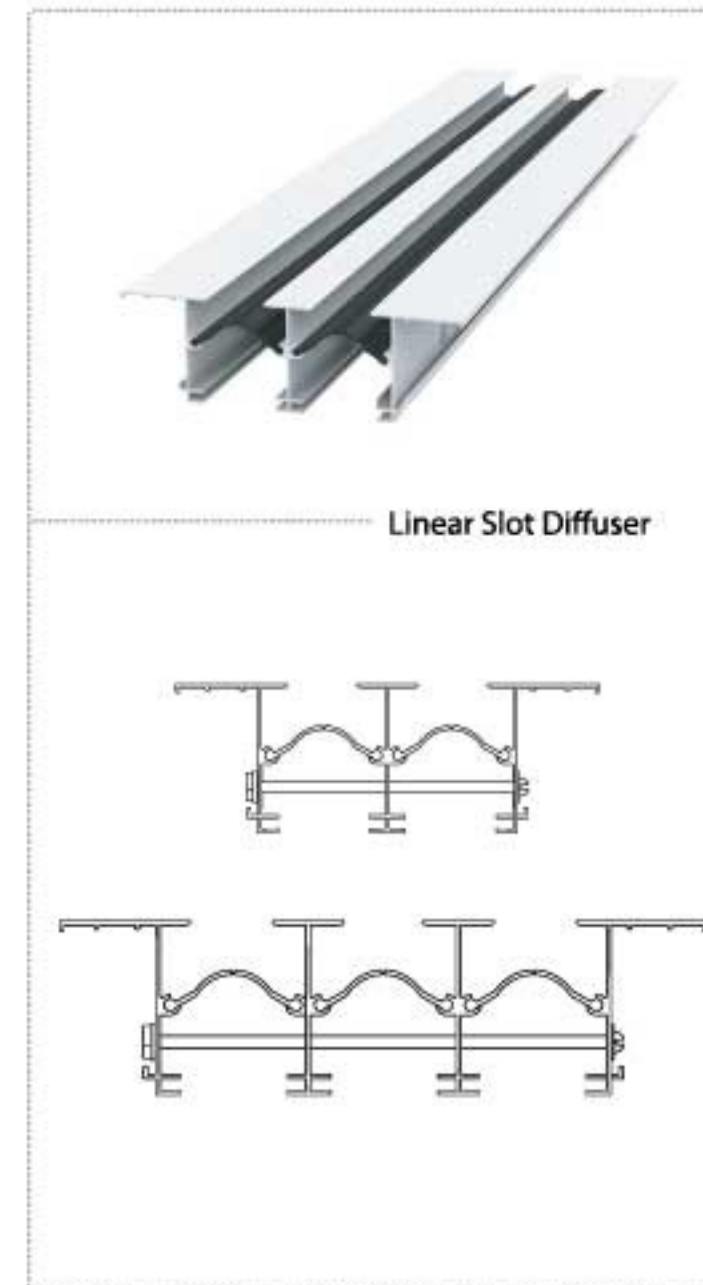
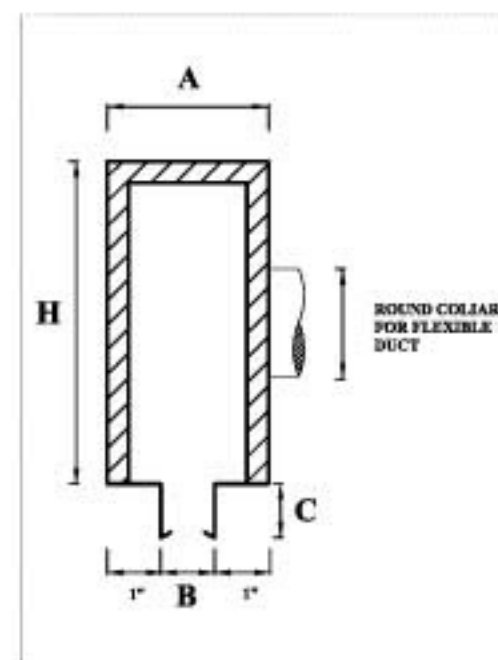

Slot Linear Grille

Capabilities:

- Air distribution with selective orientation based on the adjustment of dampers in the form of Diffusers made of aluminum
- Maximum length of per grill up to 2.8 meter and Possibility of seamless installation for an unlimited length
- Use a damper in order to control aeration
- Suitable for distribution of outlet air in Fan Coils
- Suitable for decorative assumption and front view and all types of commercial, residential and office buildings
- Use the roof up to a height of 5 meters

Plenum Box

In places where linear and slot grilles are decoratively used at long length, and since there is no possibility of uniform aeration along the top of the grill, it is necessary to use a plenum box to create adequate air mixing and uniform air distribution in length.

Plenum boxes are usually installed in long length with round entrances in distance of 1.2 meter at the back of Linear and Slot Grilles.



LINEAR SLOT DIFFUSERS



LINEAR BAR GRILLES

face velocity FPM	height (inches)	CFM per linear feet	300 deflection			
			static pre sure drop inches of water	throw in feet		NC
				side wall min-max	sill min-max	
425	4	60	0.01	8-12	2-5	20
510	3	50	0.01	8-12	2-5	20
	4	70	0.01	10-14	3-7	20
	5	90	0.01	11-16	4-9	20
	8	160	0.01	15-22	6-13	20
575	2	30	0.01	6-9	1-2	20
	4	80	0.01	11-16	4-9	20
	5	100	0.01	12-18	5-11	20
630	3	60	0.01	10-14	3-7	20
	4	90	0.02	13-18	6-11	25
	8	180	0.03	15-17	8-16	20
	10	250	0.01	21-32	-	25
	12	300	0.01	23-33	-	25
680	5	120	0.03	15-22	7-14	25
	6	140	0.01	15-22	7-14	20
	8	200	0.03	20-28	-	25
725	2	40	0.03	8-11	2-14	25
	4	100	0.03	14-20	7-13	25
	6	160	0.03	18-26	9-17	25
	12	350	0.03	26-38	-	30
770	3	70	0.03	11-16	4-9	25
	10	300	0.03	25-39	-	30
850	4	120	0.04	17-24	9-16	30
	6	180	0.04	20-30	11-21	25
	8	250	0.04	25-35	-	30
	12	400	0.04	30-44	-	35
910	2	50	0.04	10-14	3-7	25
	3	90	0.05	15-21	8-14	30
	5	160	0.04	19-29	10-20	30
	6	200	0.05	23-33	-	30
	10	350	0.03	26-38	-	30
1000	3	100	0.05	16-23	9-16	30
	4	140	0.05	19-28	11-20	30
	5	180	0.05	22-33	13-24	30
	10	400	0.05	23-50	-	40

Supply Performance Data (Liner Bar Grille 30°)

face velocity FPM	height (inches)	CFM per linear feet	static pre sure drop inches of water	0 & 150 deflection		
				throw in feet wall min-max	sill min max	NC
440	3	50		8-12	2-5	20
	4	70	0.01 0.01	10-14	3-7	20
	8	90	0.010.01	11-16	4-9	20
	5	160		15-22	8-13	20
490	2	30	0.01 0.01	6-9	1-2	20
	4	80	0.01	11-16	4-9	20
	6	120	0.01	13-19	5-11	20
520	3	60	0.01 0.01	10-14	3-7	20
	5	100	0.01	12-18	5-11	20
	8	180	0.02	17-19	8-16	20
	12	300	0.01	23-33	-	25
575	3	50	0.02	9-13	2-6	20
	4	90	0.01	13-18	6-11	25
	6	140	0.01	15-22	7-14	20
	8	200	0.02	20-28	-	25
630	10	250	0.01	21-32	-	25
	2	40	0.02	8-11	2-4	25
	3	70	0.02	11-16	4-9	25
	4	100	0.02	14-20	7-13	25
690	5	120	0.02	15-22	7-14	25
	6	160	0.02	18-26	9-17	25
	12	350	0.01	26-38	-	30
	3	80	0.03	13-18	6-11	25
725	5	140	0.02	17-25	9-17	25
	10	300	0.02	25-39	-	30
	4	120	0.03	17-24	9-16	30
780	6	180	0.03	20-30	11-21	25
	8	250	0.03	25-35	-	30
	12	400	0.03	30-44	-	35
	2	50	0.03	10-14	3-7	25
810	3	90	0.04	15-21	8-14	30
	10	300	0.03	25-39	-	30
810	5	160	0.03	19-29	10-20	30
	6	200	0.04	23-33	-	30

Supply Performance Data (Liner Bar Grille 0°)

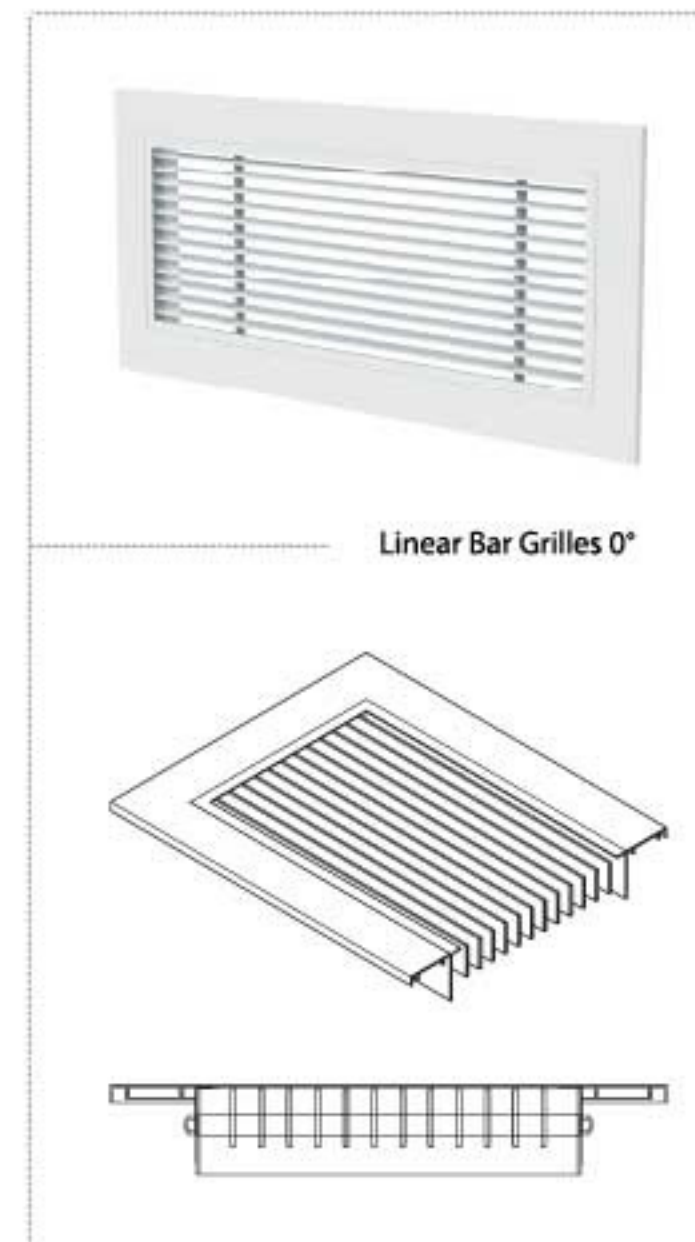
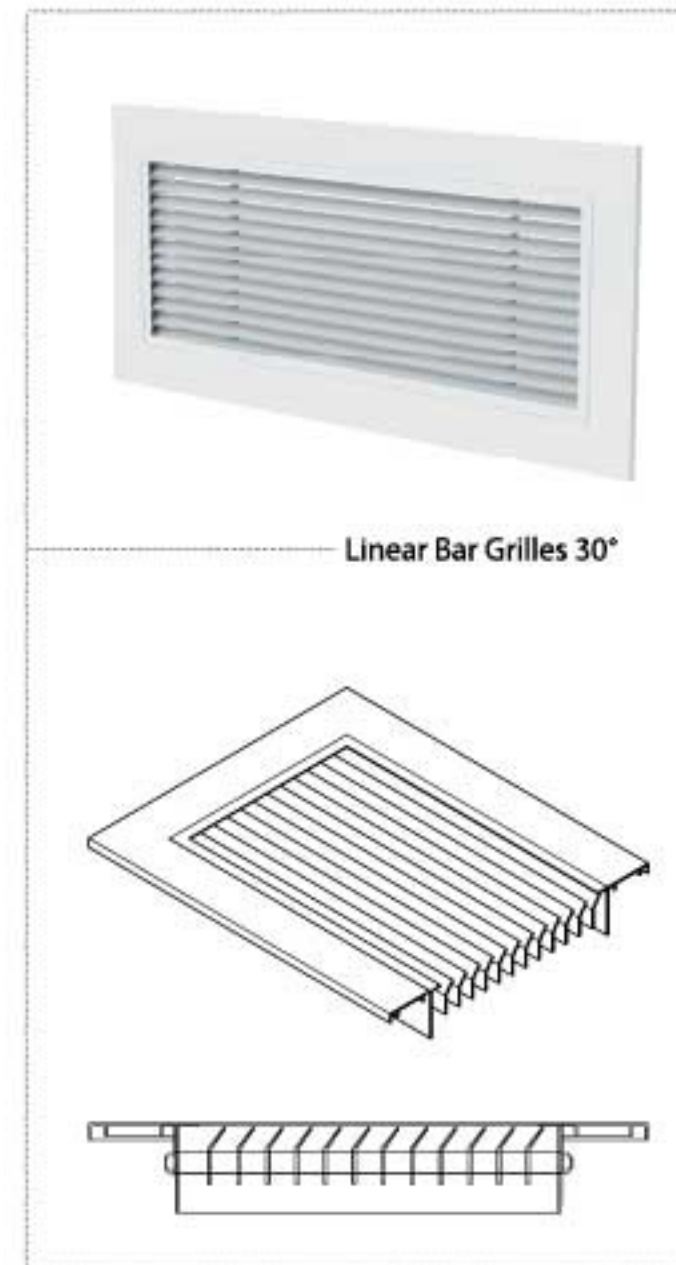

Linear Bar Grilles

Capability:

- Air distribution in direct way, 1- way, 2-way and 3-way
- Made of Aluminum
- Maximum length of grill up to 2.8 meter
- Ability to use a damper to control proper aeration to distribute exhaust air from Air Condition Systems

Application:

- All types of commercial, residential, office and luxury places
- Ceiling Height up to 5 meter

Installation Location:

- On the walls
- In front of the false ceiling
- On the ceiling

Size (inch)	Effective Area sq.ft.	AIR CAPACITIES IN CFM							
		300 FPM	400 FPM	500 FPM	600 FPM	700 FPM	800 FPM	900 FPM	1000 FPM
10X6	0.246	74	99	123	148	172	197	222	246
12X6	0.30	90	120	150	180	210	240	270	300
10X8	0.336	101	135	168	202	235	269	302	336
12X8	0.418	126	168	209	251	293	335	376	418
18X6	0.464	139	186	232	279	325	371	418	464
12X12	0.655	196	262	327	393	458	523	590	655
18X12	0.991	298	396	495	594	694	793	892	991
24X12	1.36	408	544	680	815	952	1090	1225	1360
18X18	1.56	468	625	780	935	1092	1250	1403	1560
30X12	1.70	510	680	850	1020	1190	1360	1530	1700
24X18	2.08	624	832	1040	1248	1547	1665	1872	2080
30X18	2.62	786	1050	1310	1573	1834	2098	2357	2620
24X24	2.81	843	1125	1405	1685	1970	2245	2530	2810
36X18	3.18	954	1272	1590	1910	2230	2542	2860	3180
30X24	3.54	1062	1417	1770	2125	2480	2830	3185	3540
36X24	4.28	1285	1715	2142	2570	3000	3430	3860	4280
36X30	5.42	1625	2170	2710	3250	3790	4330	4870	5420
48X24	5.72	1715	2290	2860	3430	4000	4570	5150	5720
48X30	7.34	2200	2935	3670	4400	5140	5870	6610	7340
48X36	8.71	2610	3485	4360	5220	6090	6970	7840	8710
		Negative Static Pressure (IN . H2O)							
.75 Bar Spacing		.022	.039	.059	.084	.112	.148	.187	.225

Selection Chart For Return Surgery Room Supply Grille

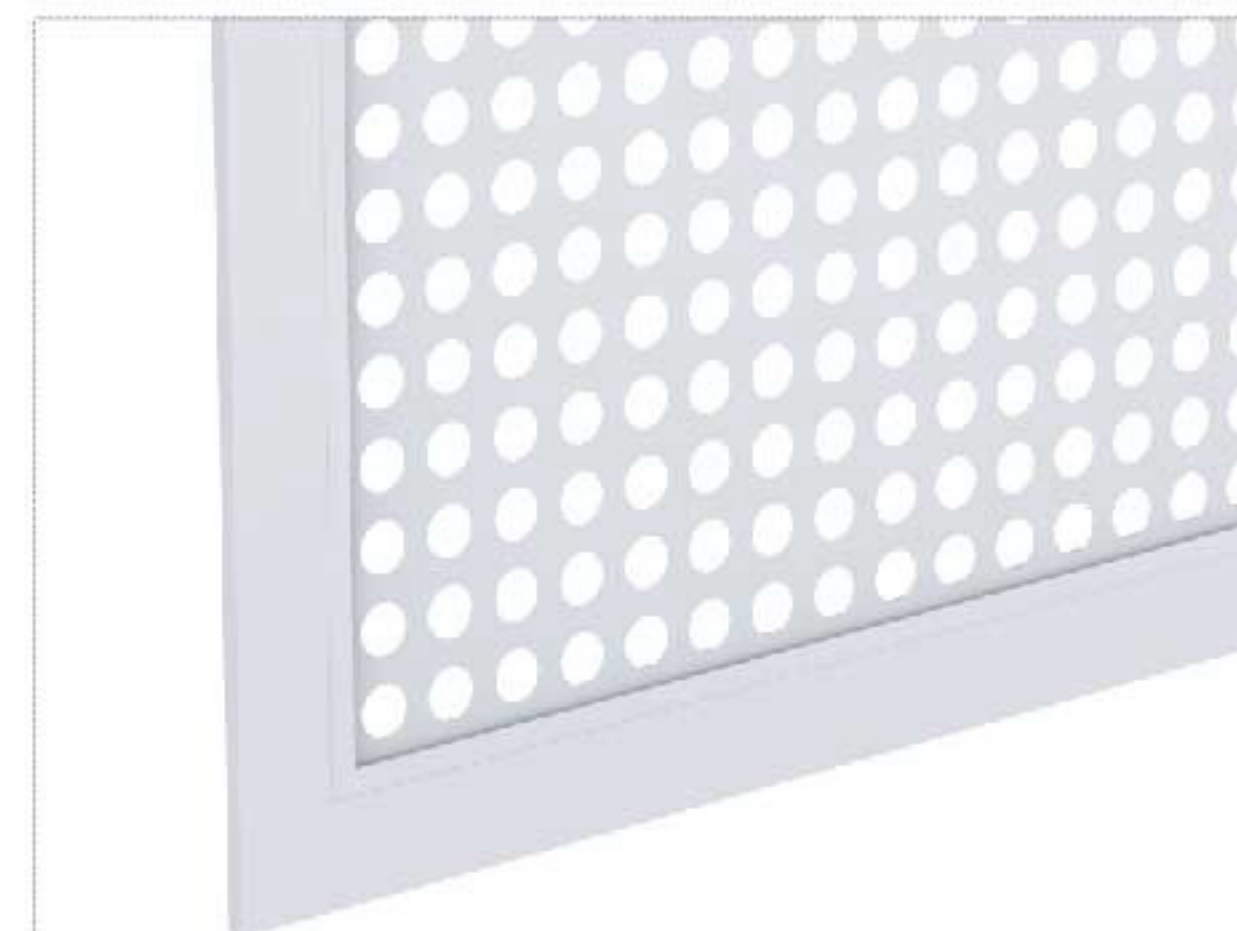
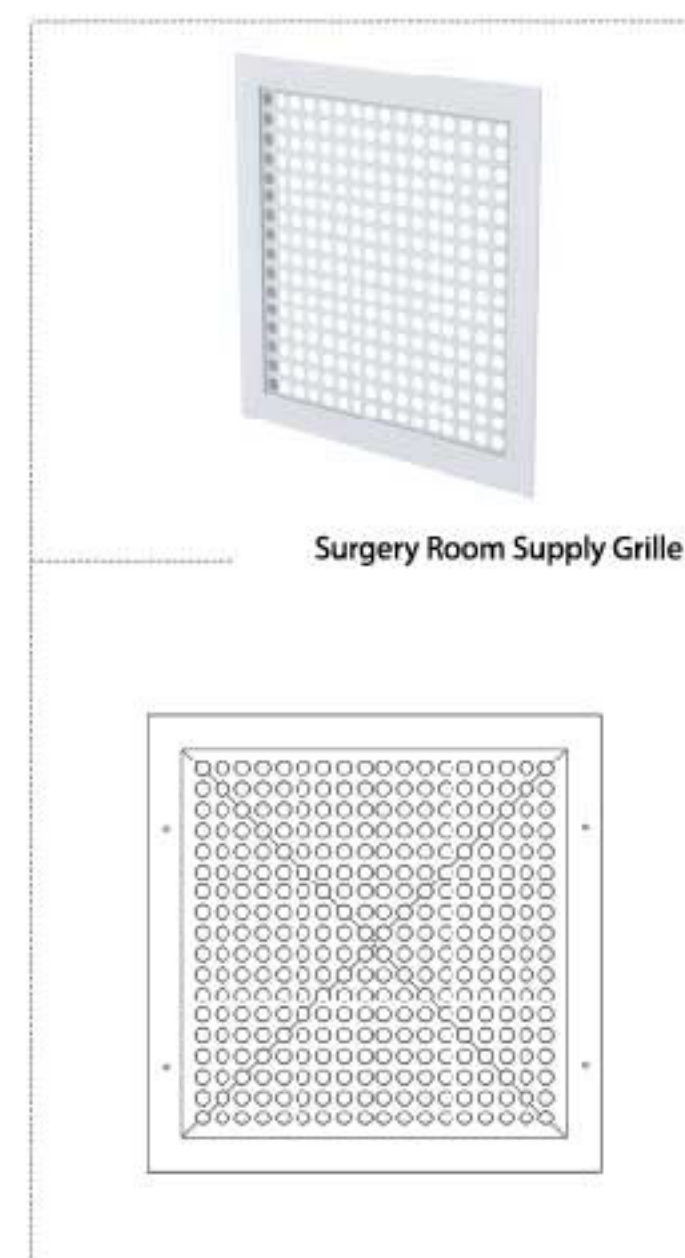

Return Surgery Room Supply Grille (Anesthesia Socket)

Surgery room return grille with anesthesia socket is installed in the return air duct of the surgery room on the wall, at an accessible height and in places where anesthesia may be performed.

Embedded anesthesia socket on the grille is used to fix the anesthesia gas pipe to discharge the remaining gas out of the surgery room with the return air flow.

In case of using wall return grilles inside the surgery rooms without any anesthesia socket, a

Surgery Room Supply Perforated Grille (Punch Model)

These grilles are used in the surgery room as supply air flow. The diffusion pattern of these grilles are gentle fall from the roof. The seamless structure of this grille minimizes the level of accumulation of pollutants on the back and the front of the grille and facilitates the act of washing and cleaning. The surgery room supply grilles is made of aluminum and usually is produced without damper behind the grilles and coated in various types of electrostatic powder colors.

		Swirl Diffuser												
m ³ /h	l/s		Supply				Exhaust with side entry plenum				Exhaust with top entry plenum			
			300-8	400-16 500-16 600-16 625-16	500-24	600-48 625-48	300-8	400-16 500-16 600-16 625-16	500-24	600-48 625-48	300-8	400-16 500-16 600-16 625-16	500-24	600-48 625-48
90	25	T	1.1											
		P _s	9											
		L _w	15											
108	30	T	1.3	1.1										
		P _s	12	3						4				
		L _w	20	-						-				
144	40	T	1.6	1.3	1.1									
		P _s	22	6	3					7				
		L _w	27	-	-					-				
180	50	T	1.9	1.4	1.3									
		P _s	34	9	4		16			12				
		L _w	33	18	-		14			12				
216	60	T	2.1	1.6	1.4									
		P _s	50	14	6		24			17				
		L _w	38	22	17		20			18				
252	70	T	2.4	1.7	1.6									
		P _s	68	18	8		32			23				
		L _w	42	26	21		24			23				
288	80	T	2.6	1.8	1.7									
		P _s	88	24	11		42	14		30	11			
		L _w	45	30	24		28	14		27	14			
360	100	T		2.0	2.0	1.8								
		P _s		38	17	5	66	21	13		47	17	12	
		L _w		36	30	-	35	21	14		33	21	13	
450	125	T		2.3	2.3	1.9								
		P _s		59	26	7	103	33	20		73	26	19	
		L _w		42	36	18	42	28	20		40	27	19	
540	150	T			2.6	2.0								
		P _s			38	10		48	29		38	27	10	
		L _w			40	23		31	26		33	25	11	
720	200	T				2.2								
		P _s				18		85	52	18		67	48	18
		L _w				31		42	35	20		42	34	20
900	250	T				2.4								
		P _s				28			82	29		75	28	
		L _w				36			42	26		41	27	
1080	300	T				2.5								
		P _s				41			118	41		108	40	
		L _w				41			47	32		46	32	
1260	350	T												
		P _s							56				55	
		L _w							37				37	
1440	400	T												
		P _s							73				72	
		L _w							41				41	
1620	450	T												
		P _s							93				91	
		L _w							44				45	

T: Throw

P_s: Pressure LossL_w: Sound Power

Swirl Diffuser



Swirl Diffuser

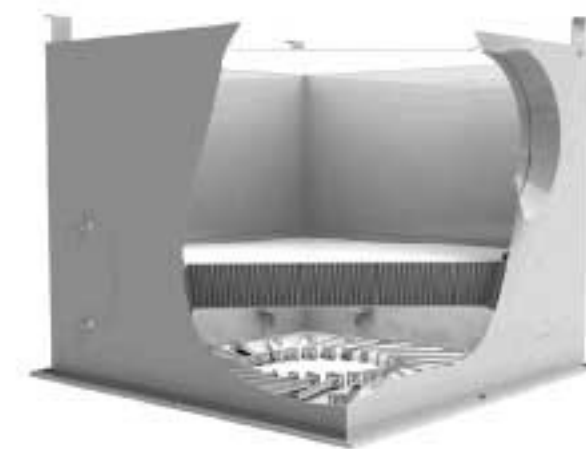

Filter Box

**Swirl Diffuser****Properties:**

It is used to create a complete mixing flow by a vortex of air (torsional model) with a long throw length.

The purpose of installing these diffusers is to eliminate the temperature gradient in the room and reach the highest possible mixing level. In different spaces where it is possible to create particles (Clean Room), the place of the installation is so important.

In order to leave the particles from the spaces, the return grilles should install in the shortest possible distance to diffusers.



Fan Coil Channel Door Grille



Fan Coil Channel Door Grille



Fan Coil Channel Door Grille



Fan Coil Channel Door Grille



Fan Coil Channel Door Grille



Fan Coil Channel Door Grille



Fan Coil Channel Door Grilles

Applications:

- In all places where two-pieces systems such as Fan Coils, Splits, VRF, are used.
- Installation under indoor units in order to access the unit and its valves for periodic repairs and services

Capabilities:

- Grilles are made of Aluminum
- Ability to create the return air of the device
- Possibility of installing supply and return grilles on a fan coil
- Possibility of installing Filters for air purification

Types of models

- Grilled with 18 mm intervals
- Mesh or Egg Crate models
- One flower and two flower in ceiling
- Linear

Models

- Hinged Access Panel for Ceiling Fan Coil with Siemens lock
- Drawer Access Panel for Ceiling Fan Coil with Siemens lock
- Weight Access Panel for Ceiling Fan Coil



Access Door

•There are usually places in the buildings that need to be visited in an emergency or in a special case, so in order to easy access to construction facilities an access door installed.

The most application of this product in Mechanical and Electrical Construction facilities section is as follows:

- In the mechanical facilities section, all accesses to sewage, sewage risers, Valves, equipment installed to control fan coils or duct fan coils, etc. can be done easily.
- In the electrical facilities also access to all Electricity , Phone , Athena ,Free Alarm Systems, Electricity Panel , Split Boxes , all Control Boxes , Computer Network, Internal telephone systems ,etc. are possible .

Application:

In all places where needed to visit and access facilities and valves.

Capabilities:

- Possibility of making aluminum
- Enabling access to building facilities and valves
- Ability to install two types of locks, Siemens and cabinet models
- Possibility of hinged door for inspection
- Possibility of construction in single glazed and double glazed type



Size	Nech Velocity(fpm) pressure (in.wg) Deflection		787	985	1180	1380	1575	1970	2360	2755	3150
			0.075	0.118	0.169	0.236	0.315	0.472	0.669	0.945	1.220
8"	Nech Area	CFM	294	353	412	471	588	706	824	942	1059
	sq.ft. 0.349	SP (in.wg)	0.076	0.120	0.169	0.233	0.305	0.474	0.670	0.927	1.220
		NC	22	27	34	37	42	47	54	58	62
		Throw(ft)	29	36	42	45	55	72	78	91	104
10"	Nech Area	CFM	412	529	647	706	824	1035	1294	1471	1648
	sq.ft. 0.545	SP (in.wg)	0.076	0.120	0.169	0.233	0.305	0.474	0.670	0.927	1.220
		NC	22	27	34	37	42	47	54	58	62
		Throw(ft)	33	43	48	57	62	79	95	114	127
12"	Nech Area	CFM	706	765	900	1059	1177	1506	1824	2118	2354
	sq.ft. 0.785	SP (in.wg)	0.076	0.120	0.169	0.233	0.305	0.474	0.670	0.927	1.220
		NC	22	27	34	37	42	47	54	58	62
		Throw(ft)	39	49	57	69	77	95	121	134	127
14"	Nech Area	CFM	824	1000	1188	1412	1618	2060	2413	2825	3237
	sq.ft. 1.069	SP (in.wg)	0.076	0.120	0.169	0.233	0.305	0.474	0.670	0.927	1.220
		NC	22	27	34	37	42	47	54	58	62
		Throw(ft)	44	56	69	77	88	108	134	157	170
16"	Nech Area	CFM	1059	1294	1559	1824	2118	2648	3237	3649	4178
	sq.ft. 1.396	SP (in.wg)	0.076	0.120	0.169	0.233	0.305	0.474	0.670	0.927	1.220
		NC	22	27	34	37	42	47	54	58	62
		Throw(ft)	52	62	77	90	105	126	1254	170	197

Selection Table For Jet Diffuser



Jet Diffuser (Long Throw)

The main property of the Jet Diffuser is that it enters the air of the channel in a projectile manner with the highest pressure in the environment. The jet nozzle model is generally used in environments are higher than usual so that the exhaust air pressure from the Jet Diffuser does not drop or decrease and maximum efficiency is achieved in air conditioning systems .

Due to the beautiful and decorative shape of the jet nozzle, the use of the Jet Diffuser is common in places which air channels are exposed in views.

Applications:

- Industrial places
- Salons, Stadiums and auditorium
- Can be installed at a ceiling height of more than 4 meters
- Ability to Install in the ceil ,on the wall and open ducts
- Air distribution is centralized and adjustable in all directions
- Placement in the frame in a variety of one, two, three and four elements
- Aeration capability up to 8000 feet per minute
- Made of aluminum
- With Square and Round frame



Jet Nozzle Diffuser



Jet Nozzle Diffuser

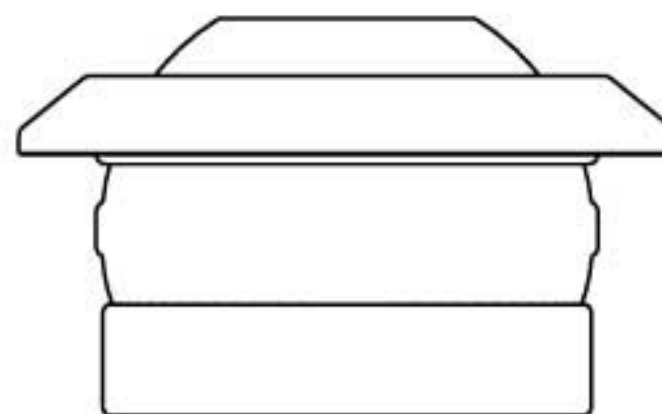

Size (inches)	Throw						Air Velocity (M/S)
	10M		20M		30M		
	CFM	NC	CFM	NC	CFM	NC	
6"Ø	85	<20	165	<20	250	33	0.25
8"Ø	105	<20	220	<20	305	25	
10"Ø	135	<20	275	<20	380	23	
12"Ø	180	<20	355	<20	540	22	
16"Ø	235	<20	465	<20	700	21	
6"Ø	165	<20	330	40	495	51	0.5
8"Ø	220	<20	435	35	655	47	
10"Ø	275	<20	550	32	825	43	
12"Ø	350	<20	700	28	1055	40	
16"Ø	465	<20	930	28	1395	39	1
6"Ø	330	40	-	-	-	-	
8"Ø	435	35	870	49	-	-	
10"Ø	550	32	1100	51	-	-	
12"Ø	700	28	1400	48	2105	54	
16"Ø	930	28	1860	43	2780	53	

Selection Table For Jet Nozzle

Jet Nozzle

The Jet Nozzle throw the air flow with high speed and acceleration to a farther distance and it is also possible to orient the air flow path.

In body of this model a spherical volume is embedded hollowly that causes the circulate in the central places and it makes possible to exist the air in the 180 circuit.

Applications:

- Industrial places
- Salons, Stadiums and auditorium
- Can be installed at a ceiling height of more than 4 meters
- Ability to Install in the ceil ,on the wall and open ducts

Capabilities:

- Air distribution is centralized and adjustable in all directions
- Placement in the frame in a variety of one, two, three and four elements
- Aeration capability up to 8000 feet per minute
- Made of aluminum

Nech dia in mm	Face velocity in m/sec	2.0	2.5	3.0	3.5	4.0	4.5	5.0	5.5	6.0
160	Cfm	51	66	78	91	106	125	137	152	172
	M ³ /sec	0.0241	0.0311	0.037	0.043	0.050	0.059	0.065	0.072	0.081
	P _s in mm H ₂ O	0.20	0.264	0.387	0.536	0.680	0.810	0.950	1.120	1.40
	Throw in m	0.9-0.5	1.1-0.7	1.3-0.9	1.6-1.1	2.0-1.5	2.5-2.0	2.9-2.4	3.4-2.8	4.0-3.3
	NC	<15	15	20	24	29	31	36	42	49
200	Cfm	72	93	117	136	155	174	195	218	248
	M ³ /sec	0.034	0.044	0.055	0.064	0.073	0.082	0.092	0.103	0.117
	P _s in mm H ₂ O	0.230	0.279	0.447	0.677	0.850	1.050	1.250	1.510	2.1
	Throw in m	1.3-0.85	1.5-1.0	1.8-1.3	2.1-1.5	2.5-1.9	2.9-2.2	3.4-2.6	4.0-3.1	4.8-3.7
	NC	<15	15	20	23	28	31	35	42	50
250	Cfm	116	146	176	23	231	258	288	320	358
	M ³ /sec	0.055	0.067	0.083	0.096	0.109	0.122	0.136	0.151	0.167
	P _s in mm H ₂ O	0.301	0.362	0.487	0.661	1.080	1.290	1.530	2.0	2.40
	Throw in m	1.6-1.1	1.9-1.4	2.4-1.8	2.7-2.0	3.0-2.2	3.5-2.5	4.2-3.0	5.0-3.6	6.0-4.4
	NC	<15	15	18	23	29	33	38	45	53
315	Cfm	177	222	267	314	354	392	437	487	542
	M ³ /sec	0.083	0.105	0.126	0.148	0.167	0.185	0.206	0.230	0.257
	P _s in mm H ₂ O	0.410	0.480	0.653	1.020	1.260	1.820	2.20	2.60	3.20
	Throw in m	1.8-1.3	2.2-1.6	2.5-2.0	3.1-2.5	3.6-3.0	4.2-3.2	4.9-3.8	5.8-4.6	7.0-5.6
	NC	<15	15	21	25	30	34	38	45	55
355	Cfm	244	297	350	413	466	530	583	639	699
	M ³ /sec	0.115	0.140	0.165	0.195	0.220	0.250	0.275	0.301	0.330
	P _s in mm H ₂ O	0.194	0.229	0.390	0.586	0.809	1.160	1.40	1.680	2.020
	Throw in m	2.0-1.4	2.5-1.7	3.1-2.4	3.6-2.7	4.2-3.0	4.7-2.3	5.6-3.9	6.7-4.6	8.1-5.6
	NC	<15	15	19	26	30	35	43	52	60
400	Cfm	2170	333	396	460	530	591	654	719	789
	M ³ /sec	0.127	0.157	0.187	0.217	0.250	0.279	0.308	0.339	0.372
	P _s in mm H ₂ O	0.163	0.192	0.309	0.469	0.589	0.827	1.10	1.40	1.70
	Throw in m	2.1-1.5	2.9-1.8	3.0-2.3	3.6-2.7	4.1-3.0	4.6-3.2	5.4-3.8	6.5-4.6	7.9-5.4
	NC	<15	15	20	25	29	34	41	50	61

- Nech size is measured in m/sec.
 - P_s: Static pressure loss in mm of H₂O.
 - Throw (meters) is measured for a terminal velocities of 0.25 & 0.5 m/sec.
 - Noise criteria (NC) based on a room attenuation of 10 dB.

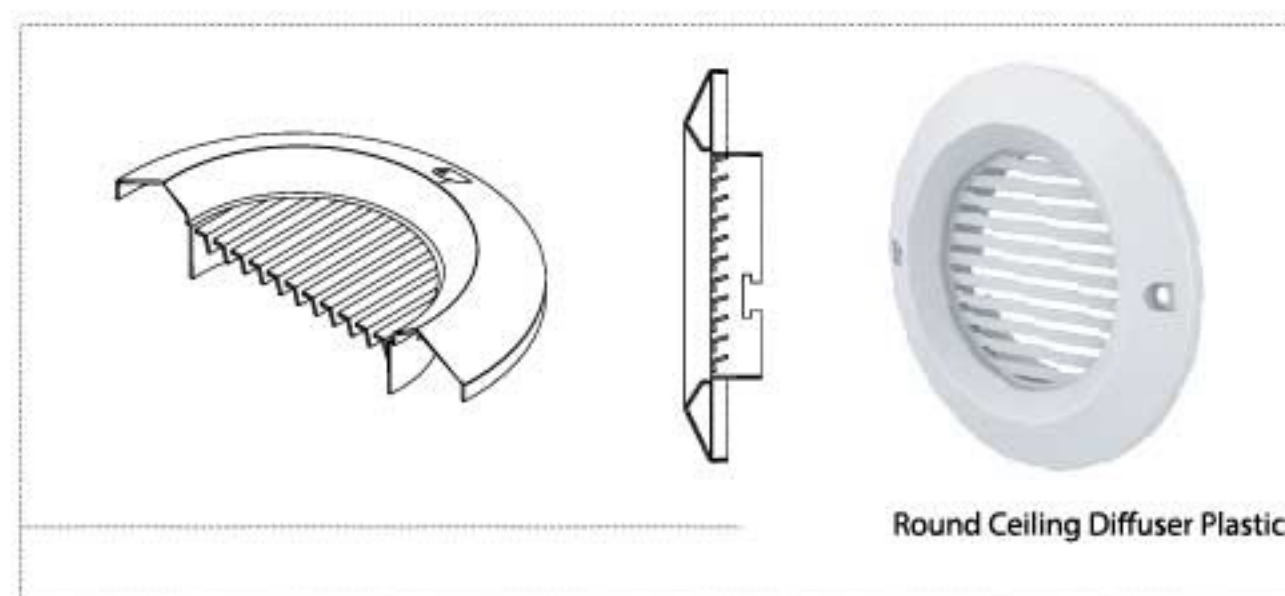
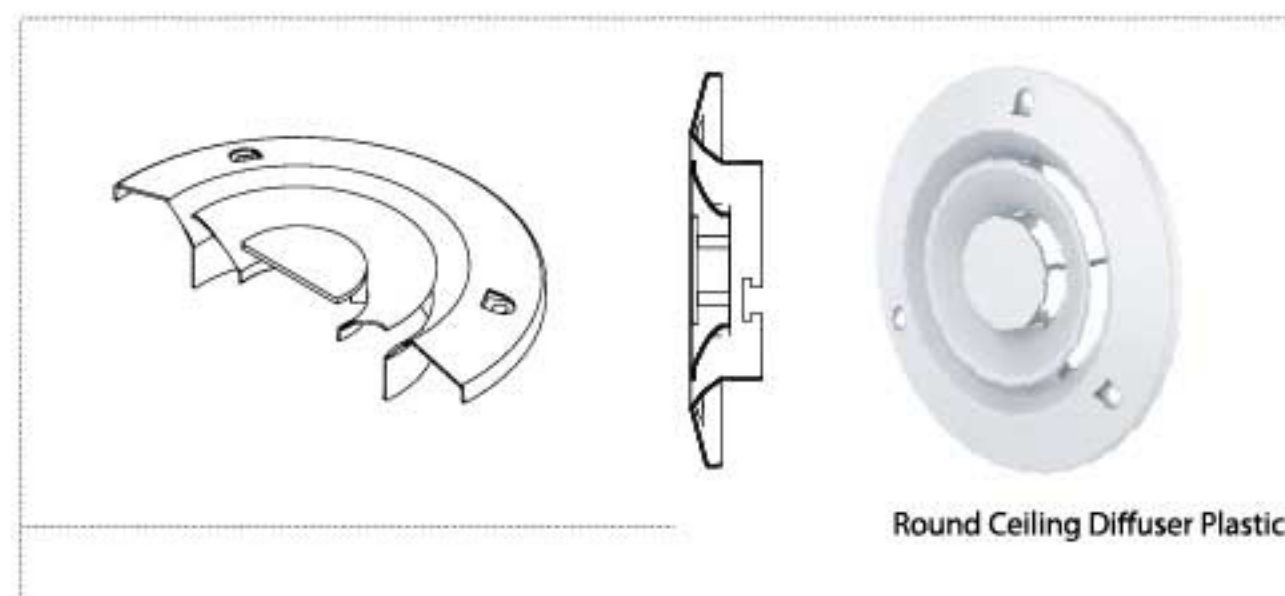
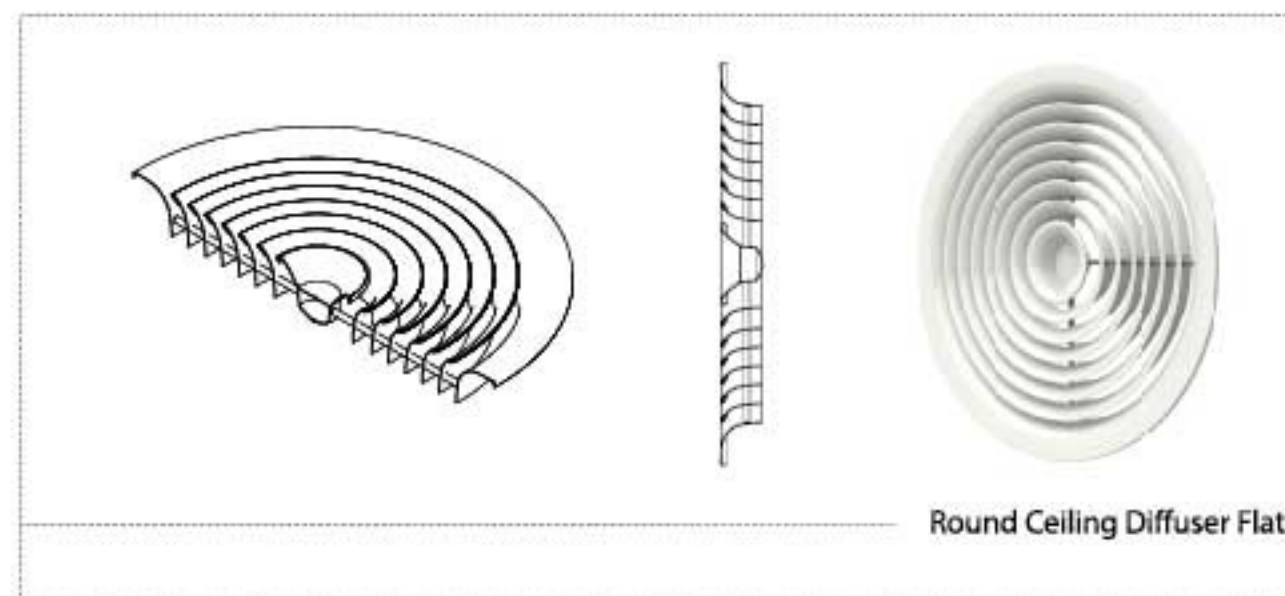
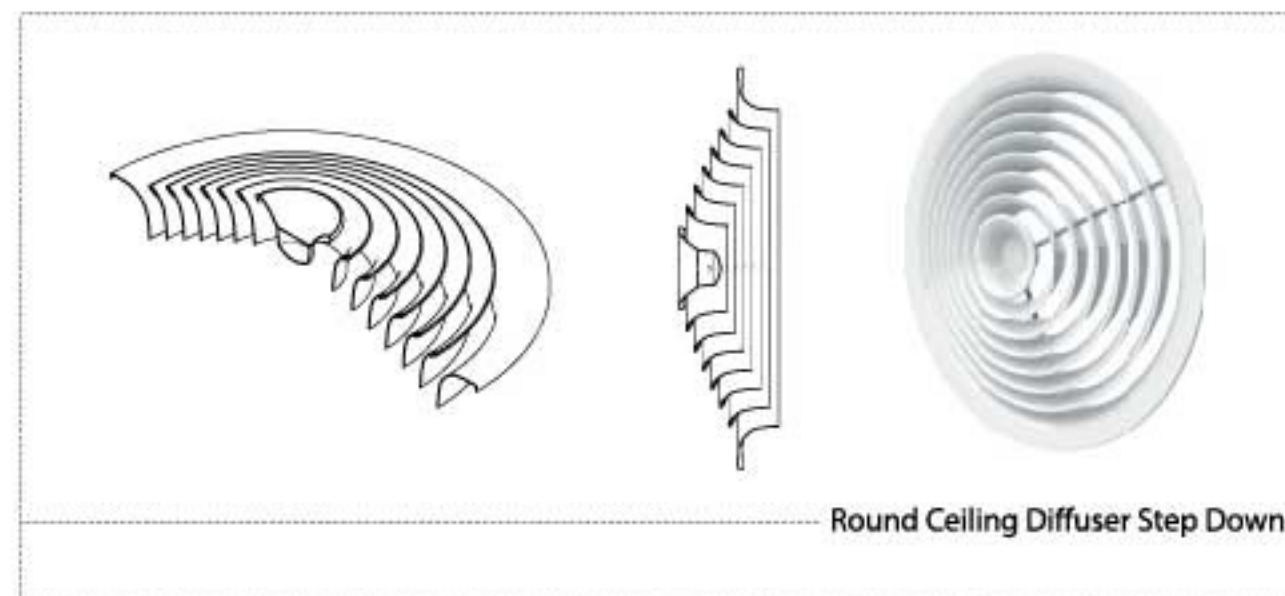

Round Diffusers

Round Diffusers as a kind of Ceiling distributor is used for air conditioning heating and cooling systems. The air distribution pattern of this type is 360 degrees and is suitable for ceilings up to 4 meters height.

Application:

- All types of office environments, Hospital and home
- Ceiling up to 4 meter
- Ability to install on the ceiling or False ceiling

Capabilities:

- Intangible air distribution as diffuser
- Aeration volume control with butterfly damper
- In two types of flat and prominent
- Aeration speed up to 2000 feet per minute



ROUND DIFFUSERS

Selection Chart For Round Ceiling Diffuser Step Down

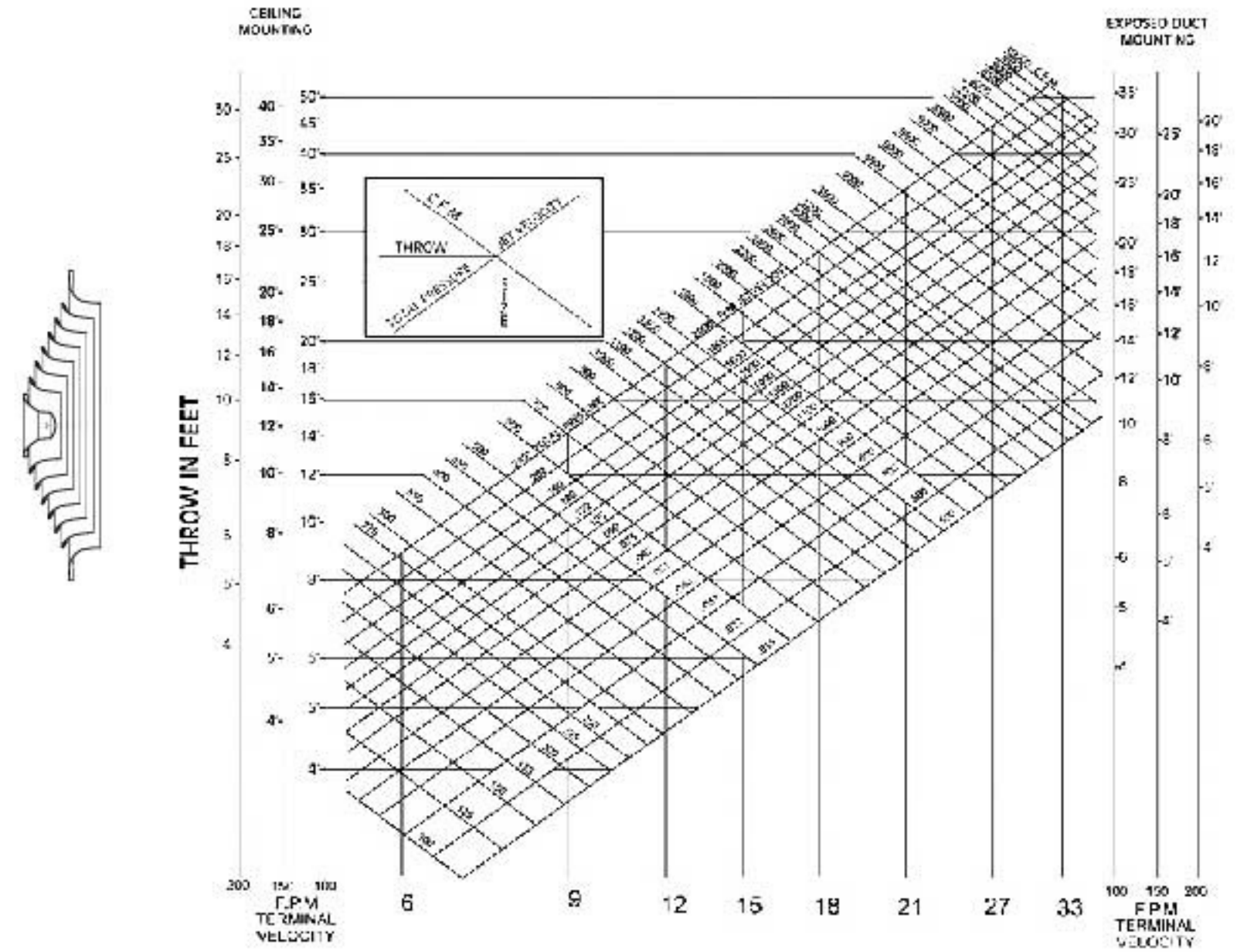

Selection Chart For Round Ceiling Diffuser Flat

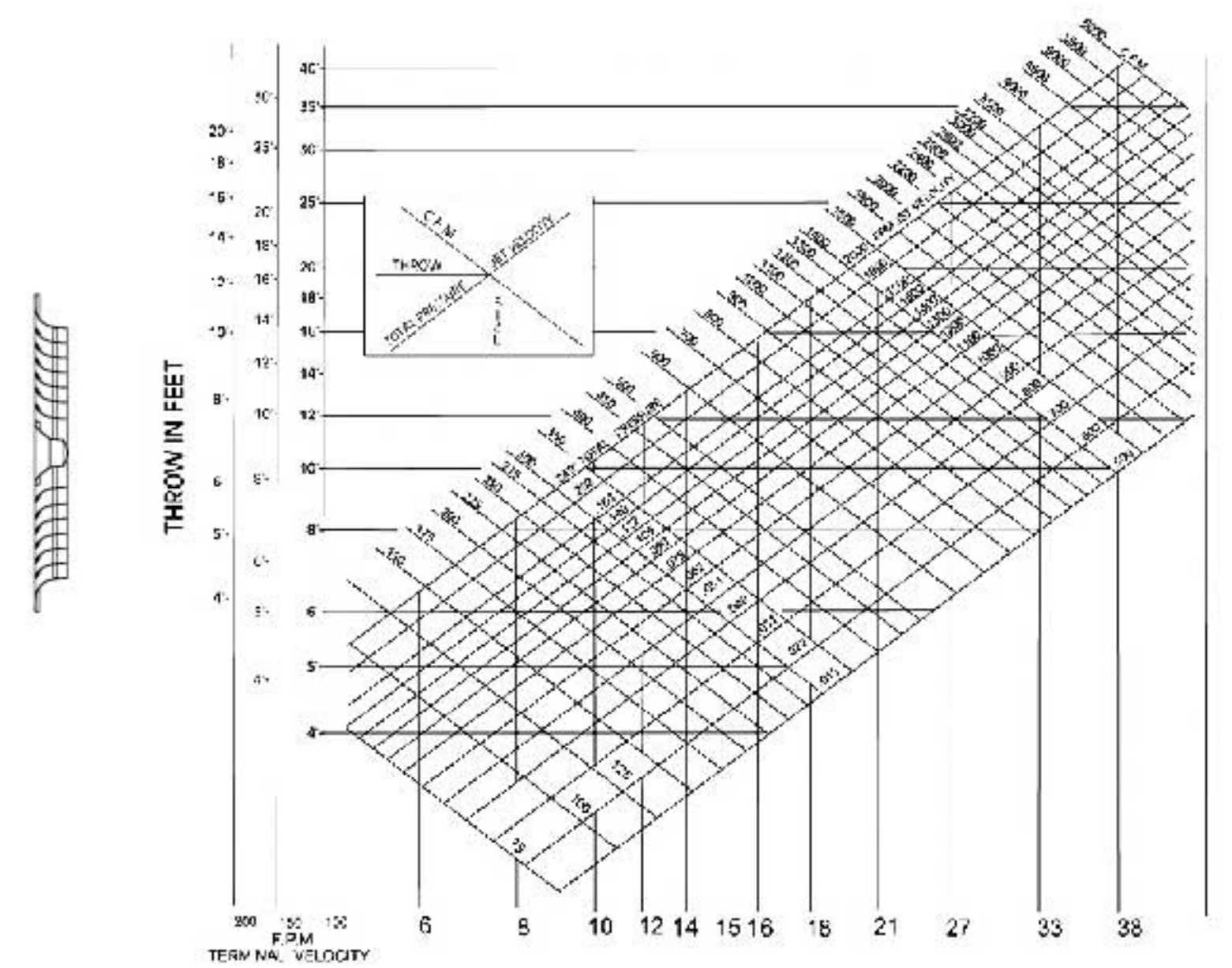



DISC VALVE

Gap size(s)	-0.25 inches	-0.12 inches	0 inches	0.25 inches	0.45 inches
CFM	nc press.	nc press.	nc press.	nc press.	nc press.
10	0.04	0.00	0.00	0.00	0.00
20	0.16	0.08	0.04	0.00	0.00
40	30 0.7	25 0.3	20 0.18	- 0.07	- 0.05
60		35 0.7	30 0.4	20 0.15	25 0.22
80		40 1.2	35 0.04	25 0.25	25 0.22
100			40 1.2	30 0.4	30 0.36
150				40 1.1	40 0.9

Selection Chart For Disc Valves - Total Pressure Drop (in wg)



Disc Valve

Disk Valve

Disk Valves are used to ventilate in bathroom and toilet (WC).

The circular part of grille's center is screwed on the grille's frame and it has ability to change the volume of aeration and the opening of the air passage by its rotation.

According to shape and structure of Disk Valve, it is easy to wash and there is no view into the channel. In this type of grille, there is no need to install a damper behind the grille.

Applications:

- Domestic consumption specially in toilet and bathroom services
- The installation location in the wall or ceiling forehead

Capabilities:

- Very low pressure drop for discharge the air
- Controlling aeration rate
- Complete closure capability
- Simple installation

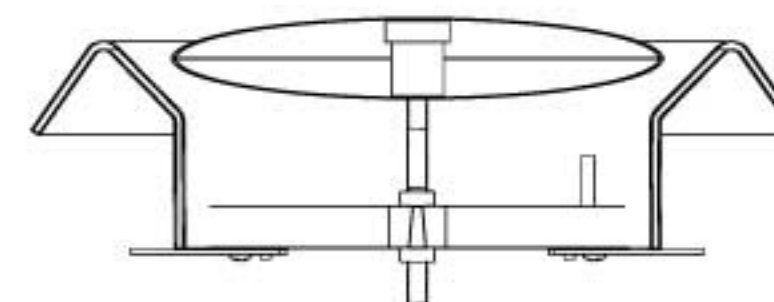

Size (Inch)	Velocity (fpm)	300	400	500	600	700	800	900	1000
	Negative St. Press. Inch W.G.	0.016	0.028	0.043	0.059	0.089	0.108	0.14	0.162
	CFM RATING (NC Level)								
12x6	0.040	121 (22)	162 (24)	202 (27)	243 (30)	283 (32)	333 (34)	363 (37)	405 (39)
12x8	0.54	162 (22)	216 (24)	270 (26)	324 (28)	380 (31)	435 (34)	485 (37)	540 (38)
16x6		170 (21)	230 (23)	275 (25)	330 (27)	392 (30)	440 (33)	498 (35)	556 (37)
18x6	0.61	170 (21)	230 (23)	275 (25)	330 (27)	392 (30)	440 (33)	498 (35)	556 (37)
12x10	0.68	207 (21)	276 (23)	345 (25)	414 (26)	483 (29)	552 (33)	621 (34)	690 (37)
20x6		243 (21)	324 (22)	405 (24)	486 (26)	567 (29)	649 (32)	729 (34)	873 (36)
12x12	0.81	243 (21)	324 (22)	405 (24)	486 (26)	567 (29)	649 (32)	729 (34)	873 (36)
18x8		304 (20)	385 (22)	481 (24)	577 (25)	674 (28)	770 (31)	866 (33)	964 (36)
18x10	1.02	304 (20)	385 (22)	481 (24)	577 (25)	674 (28)	770 (31)	866 (33)	964 (36)
30x6	1.1	320 (20)	428 (22)	531 (23)	637 (25)	744 (28)	850 (30)	955 (33)	1063 (35)
16x12		361 (20)	483 (21)	603 (22)	723 (24)	844 (26)	965 (29)	1086 (32)	1209 (34)
20x10	1.37	432 (19)	576 (21)	720 (22)	864 (23)	1008 (25)	1152 (28)	1296 (31)	1440 (34)
24x10		486 (21)	648 (21)	810 (21)	972 (23)	1134 (25)	1296 (28)	1458 (31)	1620 (33)
24x12	1.68	486 (21)	648 (21)	810 (21)	972 (23)	1134 (25)	1296 (28)	1458 (31)	1620 (33)
36x8	1.75	510 (19)	707 (20)	884 (21)	1067 (22)	1238 (24)	1415 (27)	1591 (30)	1798 (33)
30x10		593 (18)	790 (18)	988 (20)	1186 (22)	1384 (24)	1580 (27)	1778 (30)	1995 (32)
24x14	1.96	593 (18)	790 (18)	988 (20)	1186 (22)	1384 (24)	1580 (27)	1778 (30)	1995 (32)
20x18	2.18	662 (18)	889 (19)	1104 (20)	1325 (22)	1545 (24)	1774 (26)	1986 (29)	2205 (31)
30x12		839 (18)	1119 (19)	1400 (20)	1680 (21)	1959 (23)	2241 (26)	2520 (29)	2799 (30)
36x10	3.05	975 (17)	1300 (18)	1625 (20)	1950 (22)	2280 (23)	2600 (26)	2933 (28)	3290 (30)
36x14		1155 (17)	1556 (18)	1930 (19)	2319 (20)	2705 (21)	3089 (24)	3480 (27)	3861 (29)
24x24	3.48	975 (17)	1300 (18)	1625 (20)	1950 (22)	2280 (23)	2600 (26)	2933 (28)	3290 (30)
36x18	3.98	1155 (17)	1556 (18)	1930 (19)	2319 (20)	2705 (21)	3089 (24)	3480 (27)	3861 (29)
30x24	4.32	1255 (16)	1674 (17)	2095 (18)	2511 (20)	2930 (21)	3348 (23)	3767 (26)	4185 (28)
36x24	5.16	1507 (16)	2010 (17)	2511 (18)	3013 (19)	3515 (20)	4020 (22)	4519 (24)	5022 (27)

Basic Performance Data (Eqq Crate Grilles)

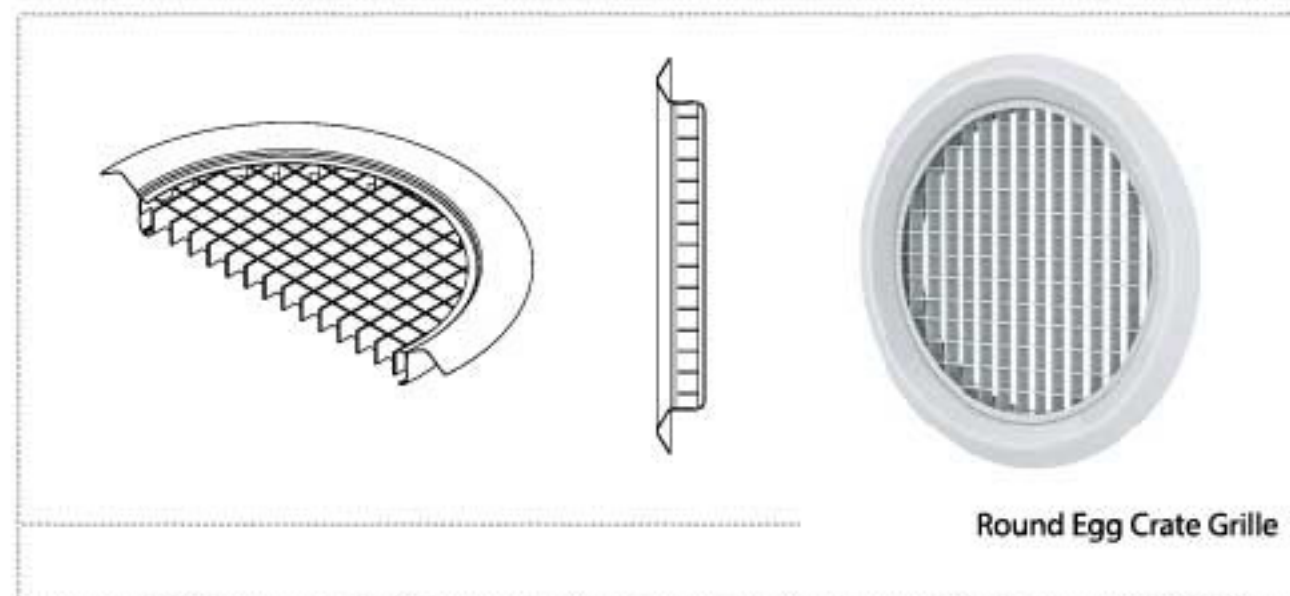

Round Egg Crate Grille

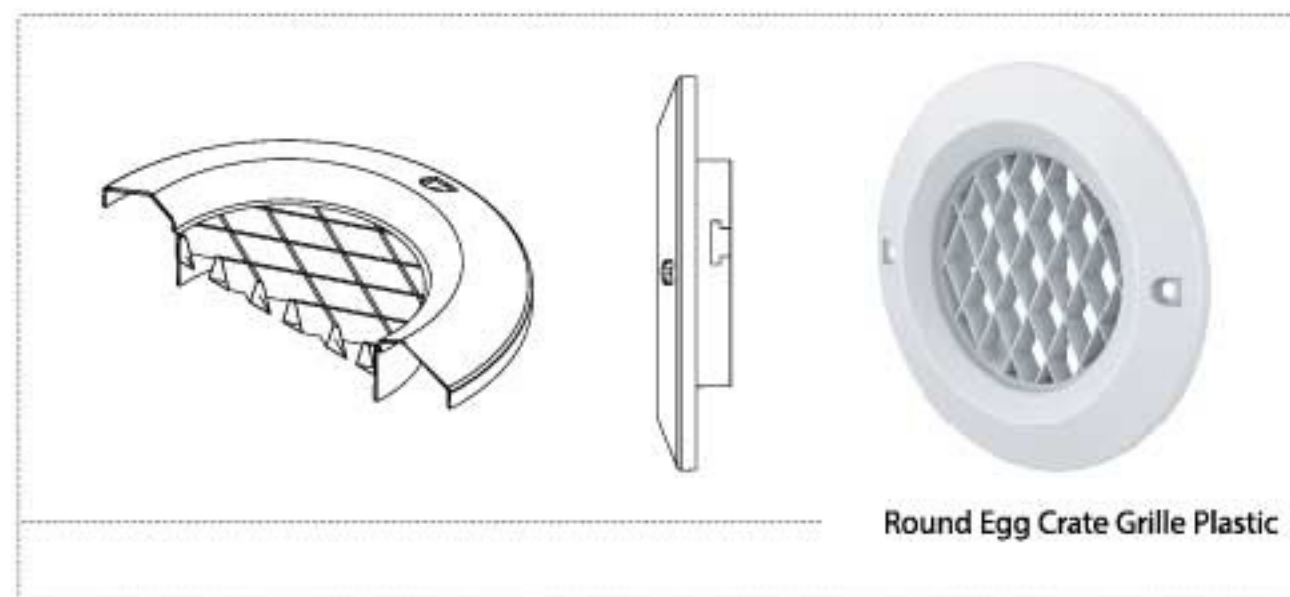

Round Egg Crate Grille Plastic

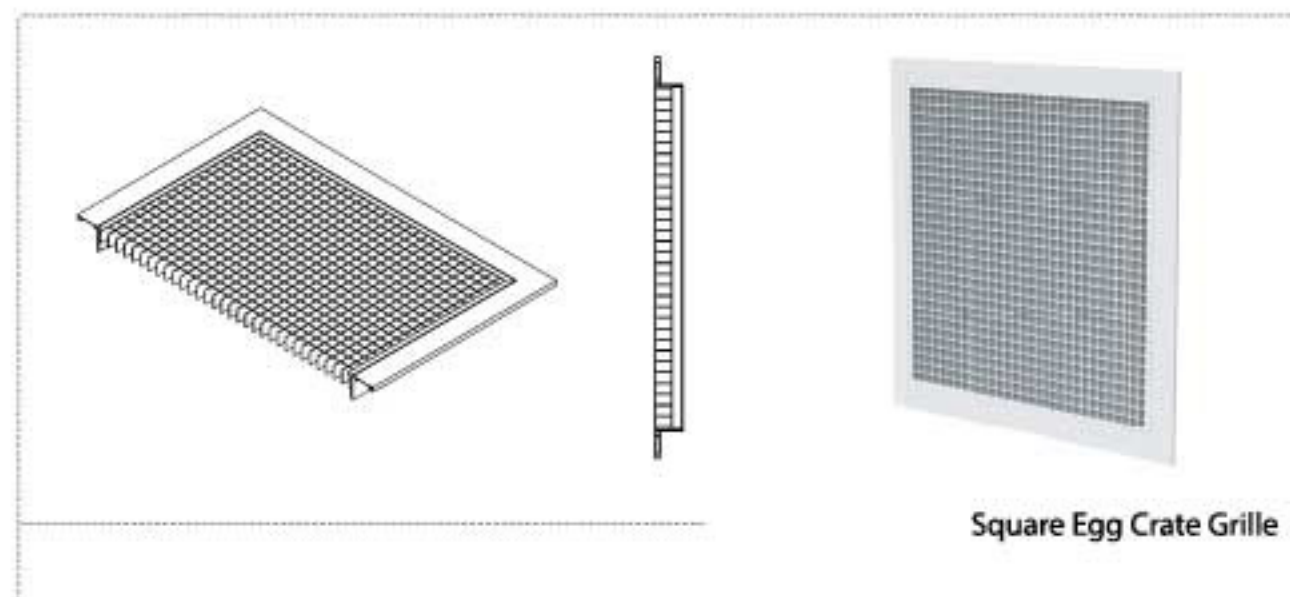

Square Egg Crate Grille

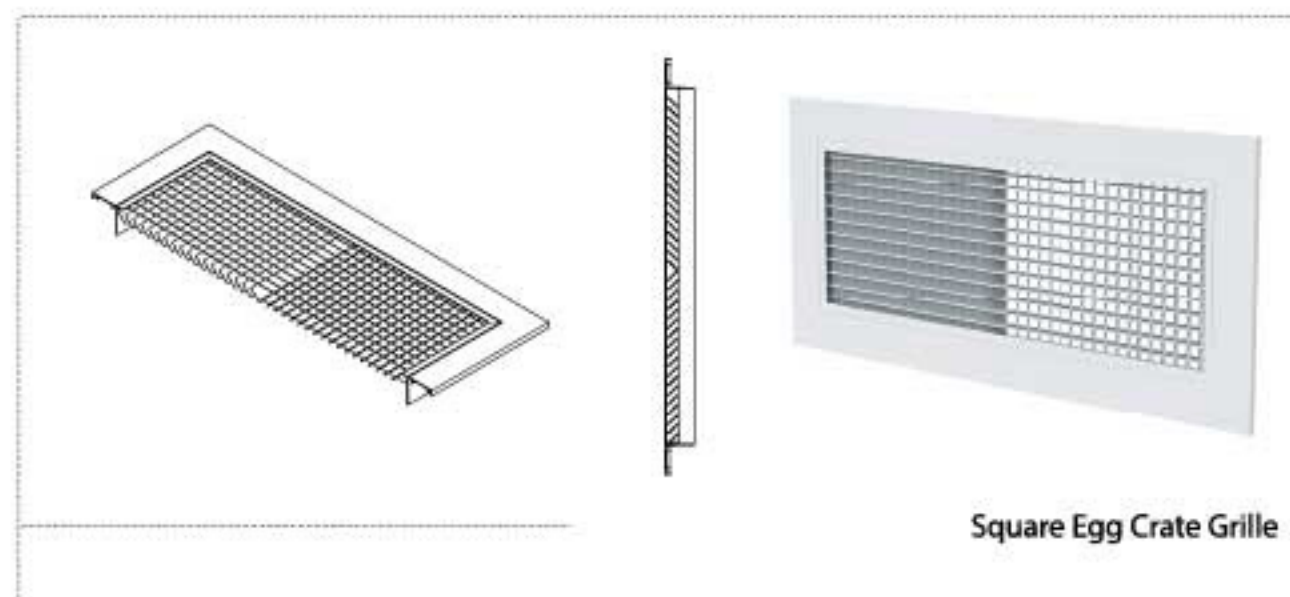

Square Egg Crate Grille

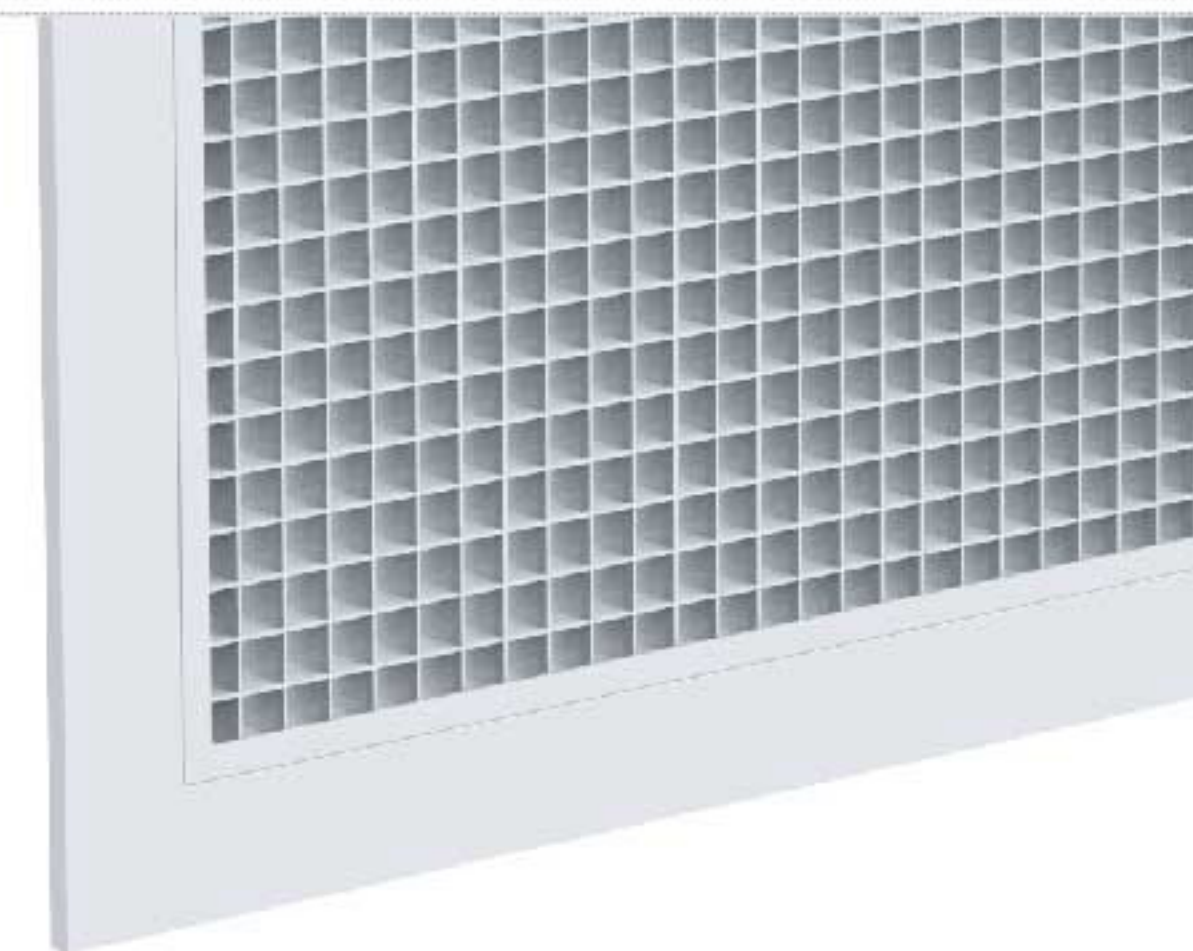

Egg Crate Grilles

These Grilles are known as Chess models, which are commonly used in air discharge ducts and in some cases on Return Air channels.

These Grilles are produced in two models, round and rectangular and there is also possibility to use of two types inside the Armstrong Tilley.

These Grilles are produced in various sizes and suitable for Ducts with diameters of 4,6,8,10,12,14,16,18,20 inches and also possible to install on the Butterfly Damper and Half plate of damper behind the grilles model . In four-square models size is customized and it is possibility to install for the damper behind the grilles in parallel and crossover types.

Applications:

Return Grilles and discharge different places

Installation Location:

- In the wall or false ceiling forehead or ceiling
- In the building facades and the hood outlet

Capabilities:

- Very low pressure drop for discharge the air
- Controlling air evacuation with damper
- It has straight blades and 45 degrees
- Possibility of aeration in one, two, three and four directions



SQUARE CEILING DIFFUSER WIDE

Vk Outlet Velocity FPM												Listed Size (in) Outlet Area
2000	1800	1500	1400	1200	1000	900	800	700	600	500		
Pr Total Pressure Inches H2O												
.25	.2	.16	.12	.09	.06	.05	.04	.03	.02	.02		
200	180	160	140	120	100	90	80	70	60	50	CFM	
6.11	5.9	5.8	4.8	4.6	3.5	3.5	2.4	2.4	2.3	2.3	X	T
6.11	5.9	5.8	4.8	4.6	3.5	3.5	2.4	2.4	2.3	2.3	Y	T
450	410	360	315	270	225	205	180	155	135	110	CFM	
8.14	7.13	6.12	6.11	5.9	5.8	4.6	3.5	3.5	2.4	2.4	X	T
8.14	7.13	6.12	6.11	5.9	5.8	4.6	3.5	3.5	2.4	2.4	Y	T
800	725	640	560	480	400	360	320	280	240	206	CFM	
10.19	9.17	8.15	7.13	6.12	6.11	5.9	5.8	4.8	4.6	3.5	X	T
10.19	9.17	8.15	7.13	6.12	6.11	5.9	5.8	4.8	4.6	3.5	Y	T
1250	1125	1000	875	750	625	565	500	440	375	310	CFM	
13.23	12.21	10.19	10.18	8.15	6.12	6.11	6.11	5.9	4.8	4.6	X	T
13.23	12.21	10.19	10.18	8.15	6.12	6.11	6.11	5.9	4.8	4.6	Y	T
1800	1620	1440	1260	1080	900	810	720	630	540	450	CFM	
16.30	15.27	13.23	11.20	10.17	8.5	7.13	6.12	5.11	5.9	4.8	X	T
16.30	15.27	13.23	11.20	10.17	8.5	7.13	6.12	5.11	5.9	4.8	Y	T
2460	2220	1970	1725	1475	1230	1110	985	860	740	615	CFM	
19.35	17.31	15.29	13.25	11.21	9.17	9.15	8.14	7.13	6.11	5.9	X	T
19.35	17.31	15.29	13.25	11.21	9.17	9.15	8.14	7.13	6.11	5.9	Y	T
3200	2890	2570	2240	1925	1600	1440	1275	1120	960	800	CFM	
20.39	18.35	16.31	14.29	12.23	10.19	9.17	8.15	7.14	7.13	5.11	X	T
20.39	18.35	16.31	14.29	12.23	10.19	9.17	8.15	7.14	7.13	5.11	Y	T
4040	3650	3240	2840	2430	2020	1820	1615	1420	1215	1010	CFM	
23.42	20.38	18.35	16.32	14.27	12.22	10.19	10.18	8.15	7.13	6.12	X	T
23.42	20.38	18.35	16.32	14.27	12.22	10.19	10.18	8.15	7.13	6.12	Y	T
5500	4950	4400	3850	3300	2750	2470	2200	1925	1650	1370	CFM	
31.50	27.46	23.41	19.37	18.33	16.27	14.24	12.21	10.18	9.16	7.13	X	T
31.50	27.46	23.41	19.37	18.33	16.27	14.24	12.21	10.18	9.16	7.13	Y	T

4 Way Engineering Performance Data.

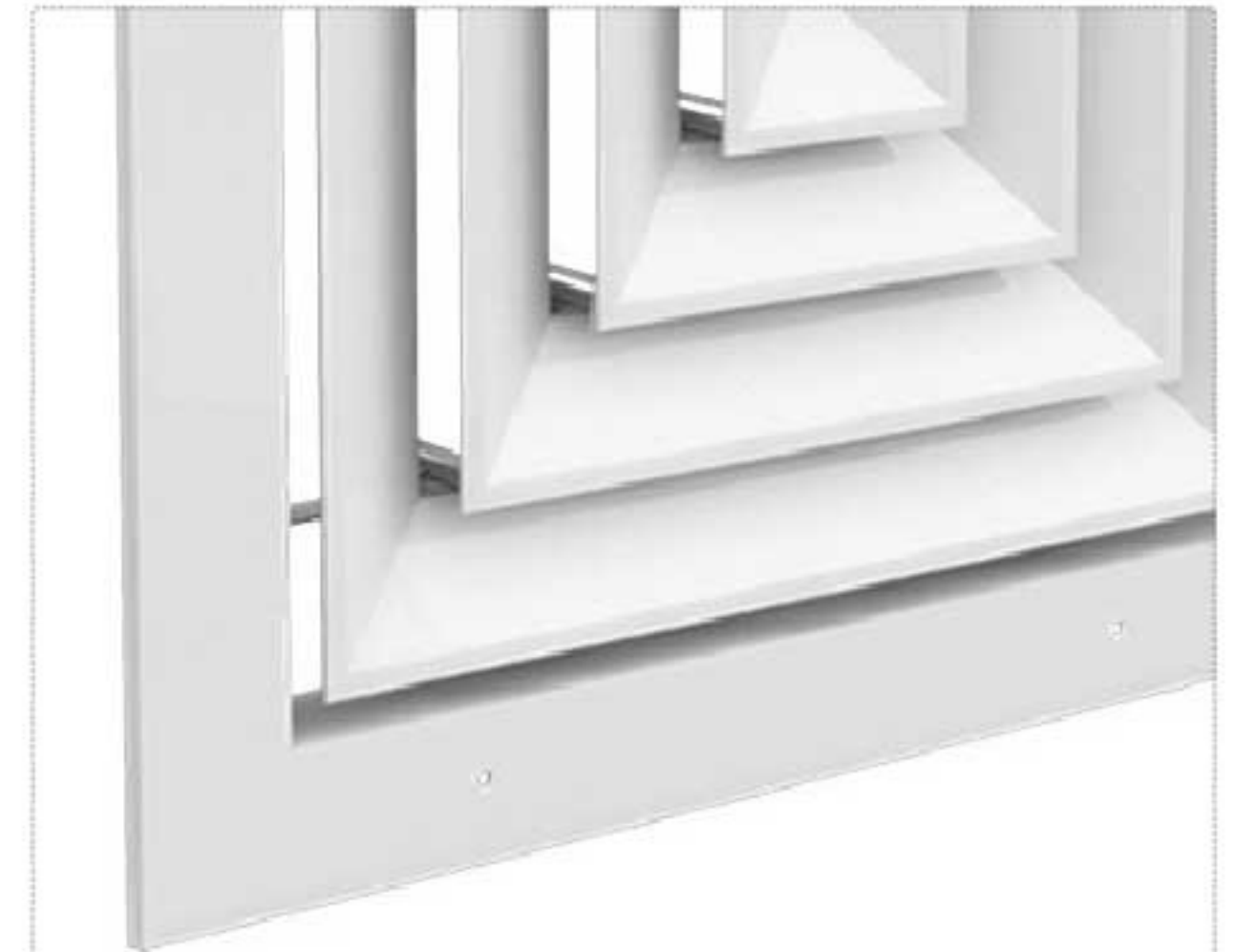
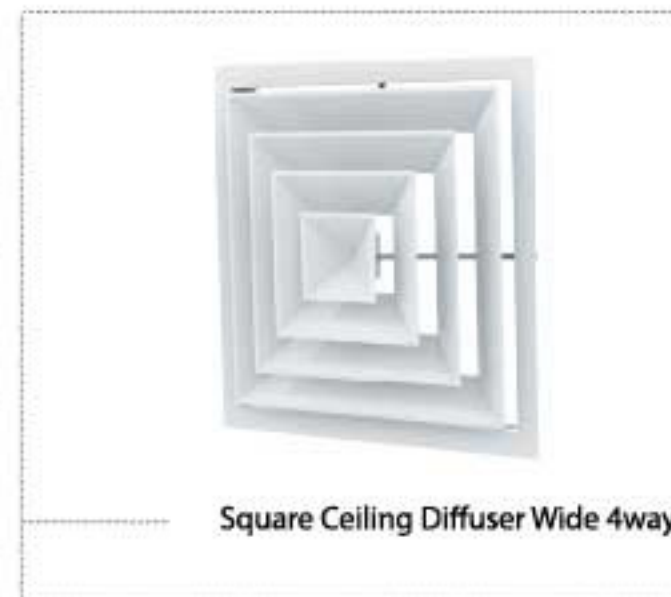
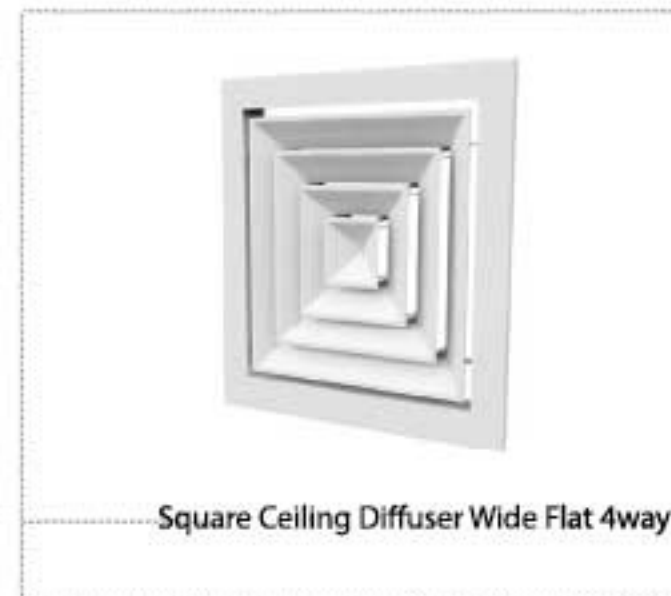
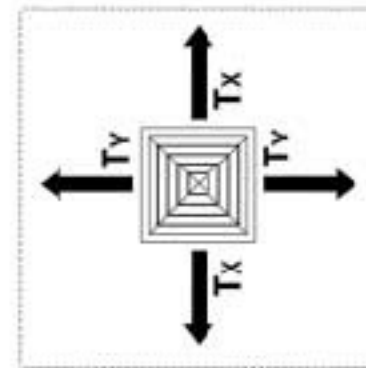

Square Ceiling Diffuser Wide

Application:

- All types of Commercial buildings , Office , Luxury places and Hospital
- Ceiling height up to 5 meter
- Ability to install inside in the wall or false ceilings or ceilings
- Used for exhaust and in some cases return air.

Capabilities:

- Air distribution with selective orientation as diffuser model
- Ability to produce Aluminum and Iron
- Ability to use dampers to control aeration
- Suitable for distributing exhaust air from fan coils
- Suitable for decorative consumptions in ceiling and on the wall

Vk Outlet Velocity FPM												Listed Size (in) Outlet Area
2000	1800	1500	1400	1200	1000	900	800	700	600	500		
Pr Total Pressure Inches H2O												
.25	.2	.16	.12	.09	.06	.05	.04	.03	.02	.02		
180	160	140	125	105	90	80	70	60	55	45	CFM	
9.14	8.13	7.12	6.11	5.8	5.8	3.7	3.7	2.5	2.5	1.3	X	T
9.14	8.13	7.12	6.11	5.8	5.8	3.7	3.7	2.5	2.5	1.3	Y	T
390	350	315	275	235	195	175	155	135	115	95	CFM	
14.22	13.20	10.16	9.14	8.13	6.11	6.10	5.8	5.7	4.6	4.6	X	T
14.22	13.20	10.16	9.14	8.13	6.11	6.10	5.8	5.7	4.6	4.6	Y	T
700	635	560	480	420	350	315	280	245	210	175	CFM	
19.29	16.26	14.22	13.19	10.16	9.14	8.13	8.13	6.11	5.8	5.7	X	T
19.29	16.26	14.22	13.19	10.16	9.14	8.13	8.13	6.11	5.8	5.7	Y	T
110	995	885	775	660	550	495	440	385	330	275	CFM	
23.36	21.33	19.29	15.25	13.21	11.18	10.16	9.14	8.13	7.12	5.9	X	T
23.36	21.33	19.29	15.25	13.21	11.18	10.16	9.14	8.13	7.12	5.9	Y	T
1560	1410	1250	1090	935	780	700	625	545	470	390	CFM	
28.42	25.38	21.30	18.29	16.25	14.22	12.19	10.16	10.15	9.14	7.12	X	T
28.42	25.38	21.30	18.29	16.25	14.22	12.19	10.16	10.15	9.14	7.12	Y	T
2160	1945	1730	1515	1300	1080	975	865	760	650	540	CFM	
32.47	29.43	25.39	22.35	20.32	17.28	15.23	13.21	12.18	10.15	8.13	X	T
32.47	29.43	25.39	22.35	20.32	17.28	15.23	13.21	12.18	10.15	8.13	Y	T
2820	2510	2250	1950	1690	1410	1270	1130	990	845	705	CFM	
37.51	33.47	29.42	25.38	22.34	19.29	17.27	15.24	13.21	11.18	9.16	X	T
37.51	33.47	29.42	25.38	22.34	19.29	17.27	15.24	13.21	11.18	9.16	Y	T
3520	3170	2820	2470	2110	1760	1585	1410	1230	1055	880	CFM	
39.55	35.50	32.46	28.41	24.37	21.33	19.29	16.26	14.22	12.19	10.17	X	T
39.55	35.50	32.46	28.41	24.37	21.33	19.29	16.26	14.22	12.19	10.17	Y	T

2 Way Engineering Performance Data.

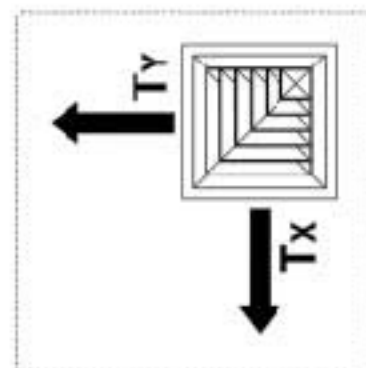

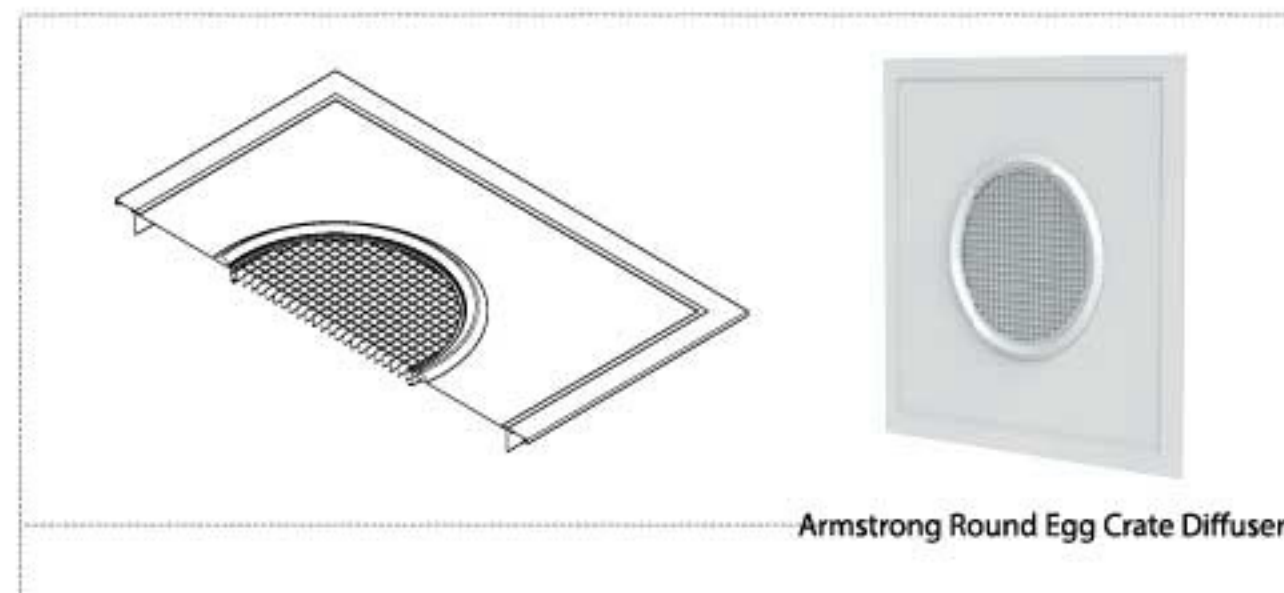
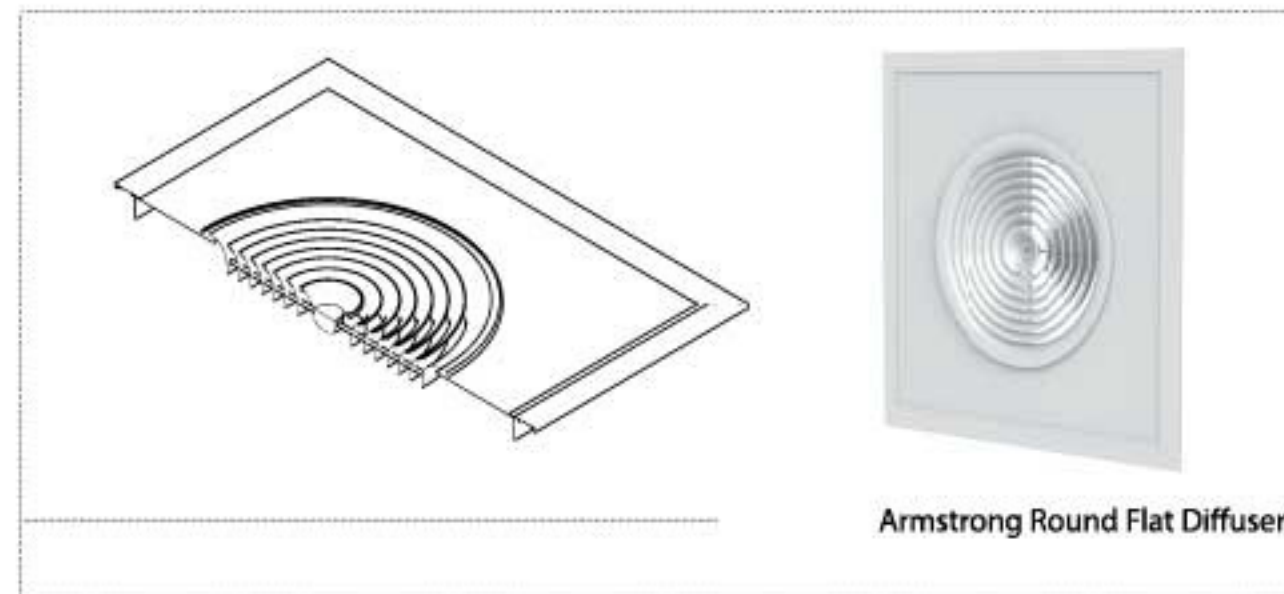
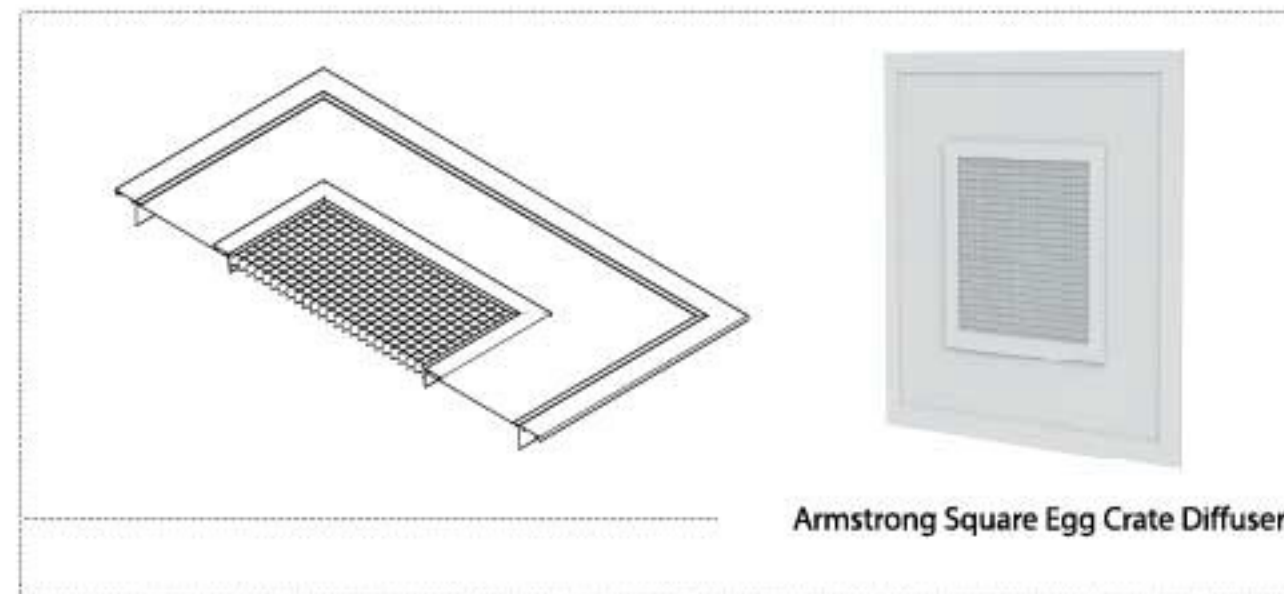
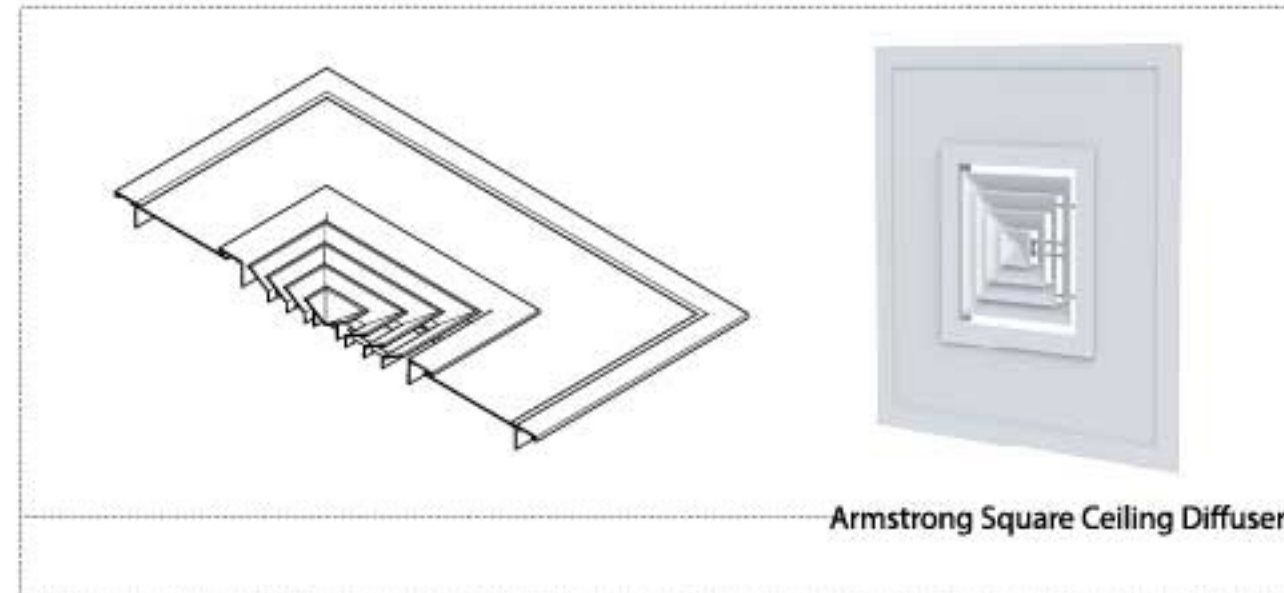

Armstrong Diffusers

Armstrong Tiles as grid and seamless false ceilings are made of galvanized structure in a variety of Gypsum, PVC, Acoustic or Aluminum tiles, which have high capabilities in design and speed in the implementation of various office projects and bathroom's ceiling.

Application

Special for Armstrong false ceiling tiles.

Capabilities:

- Very easy installation and highly flexibility using converters with different dimensions to connect to the channel
- Beautiful and decorative appearance for a variety of home consumptions , office , restaurant ,hotels and hospitals

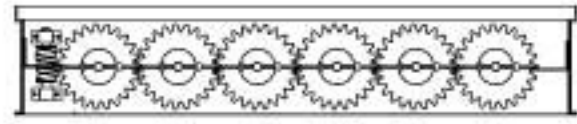

Round Egg Crate Grille Plastic



Round Egg Crate Grille

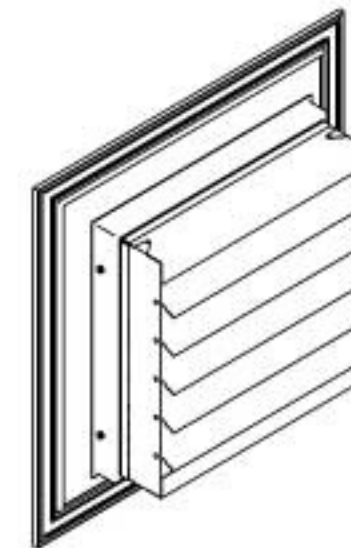
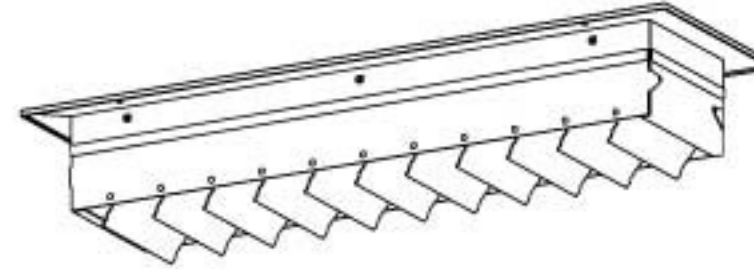
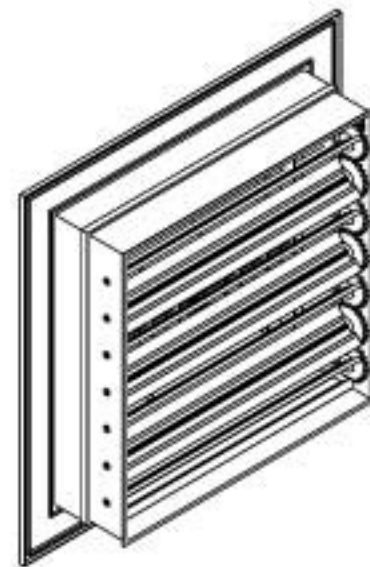
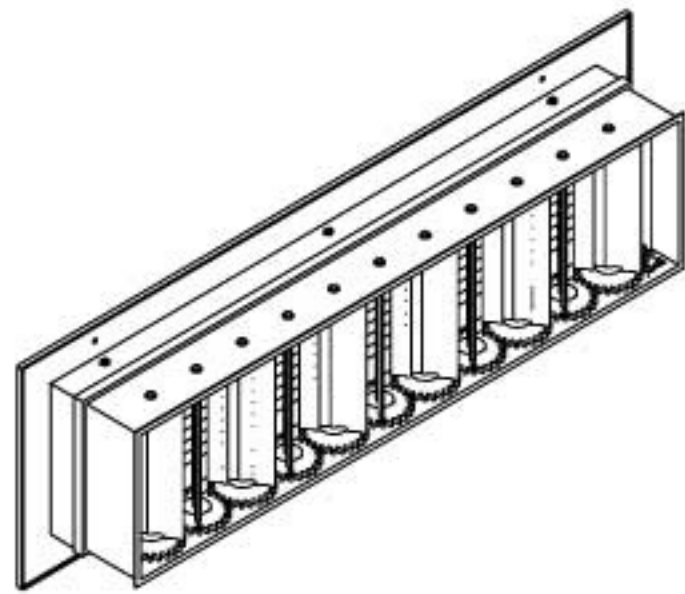

Damper behind the grilles & registers Parallel and Opposed dampers

These dampers are switched by On/Off and produced in Screwdriver, Volumetric and Lever models.

The Volumetric Damper behind the grilles are installed at the back and inside the channels of the air, since it has a lever adjustment, opening and closing of the blades can be well controlled and the CFM (Cubic Feet per Minute) of the air can be adjusted.

Butterfly Damper

A butterfly damper is used to adjust the amount of air passing through the round grilles. Due to the way of opening model of the blades of this type of damper, the air distribution from the grille remains almost symmetrical.

Half Plate Damper

Half-Plate dampers are installed on the round grilles. Due to the way the damper blade opens, this model as an air damper in parts of the channel that cannot be branched, is used. During installing the blade should be such that it guides air to the grille when opened.

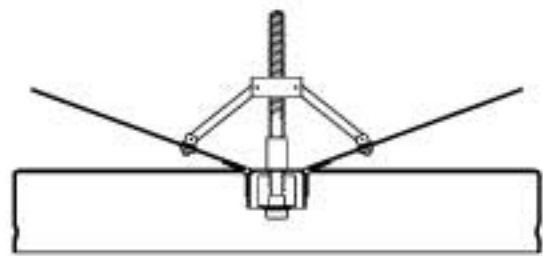

Butter Fly Damper

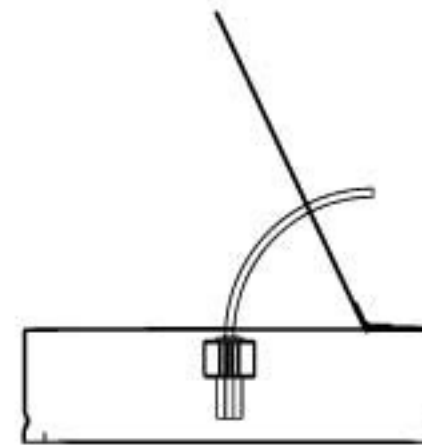

Half Plate Damper

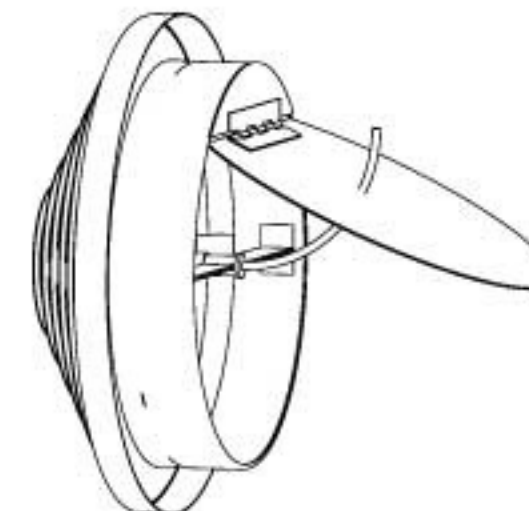
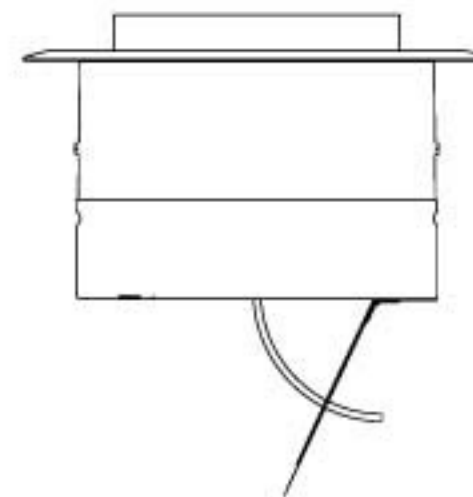
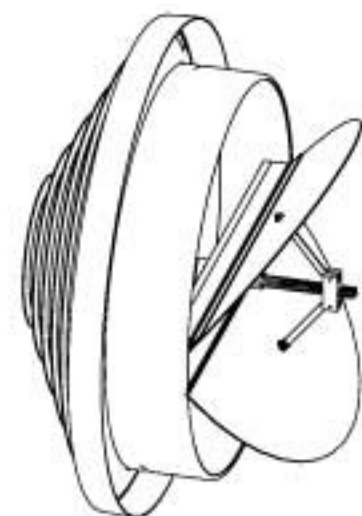
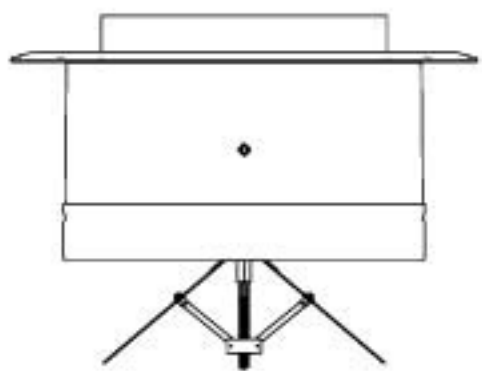

Louver Size (inch)	Max. CFM	Louver Size	Max. CFM	Louver Size	Max. CFM
12x12	400	60x24	4000	84x42	9800
18x12	600	30x30	2500	96x42	11200
24x12	800	36x30	3000	48x48	6400
30x12	1000	42x30	3500	60x48	8000
36x12	1200	48x30	4000	72x48	9600
42x12	1400	60x30	5000	84x48	11200
48x12	1600	72x30	6000	96x48	12800
18x18	900	36x36	3600	60x60	10000
24x18	1200	42x36	4200	72x60	12000
30x18	1500	48x36	4800	84x60	14000
36x18	1800	60x36	6000	96x60	16000
42x18	2100	72x36	7200	108x60	18000
48x18	2400	84x36	8400	72x72	14400
24x24	1600	96x36	9600	84x72	16800
30x24	2000	42x42	4900	96x72	19200
36x24	2400	48x42	5600	108x120	21600
42x24	2800	60x42	7000	120x72	24000
48x24	3200	72x42	8400	144x72	28800

Selection Chart For Intake Louver

Note:

Above capacities are based on 200 FPM on gross area, 50% free area and 0.2" WG loss through louver and 1/2 mesh brid screen.

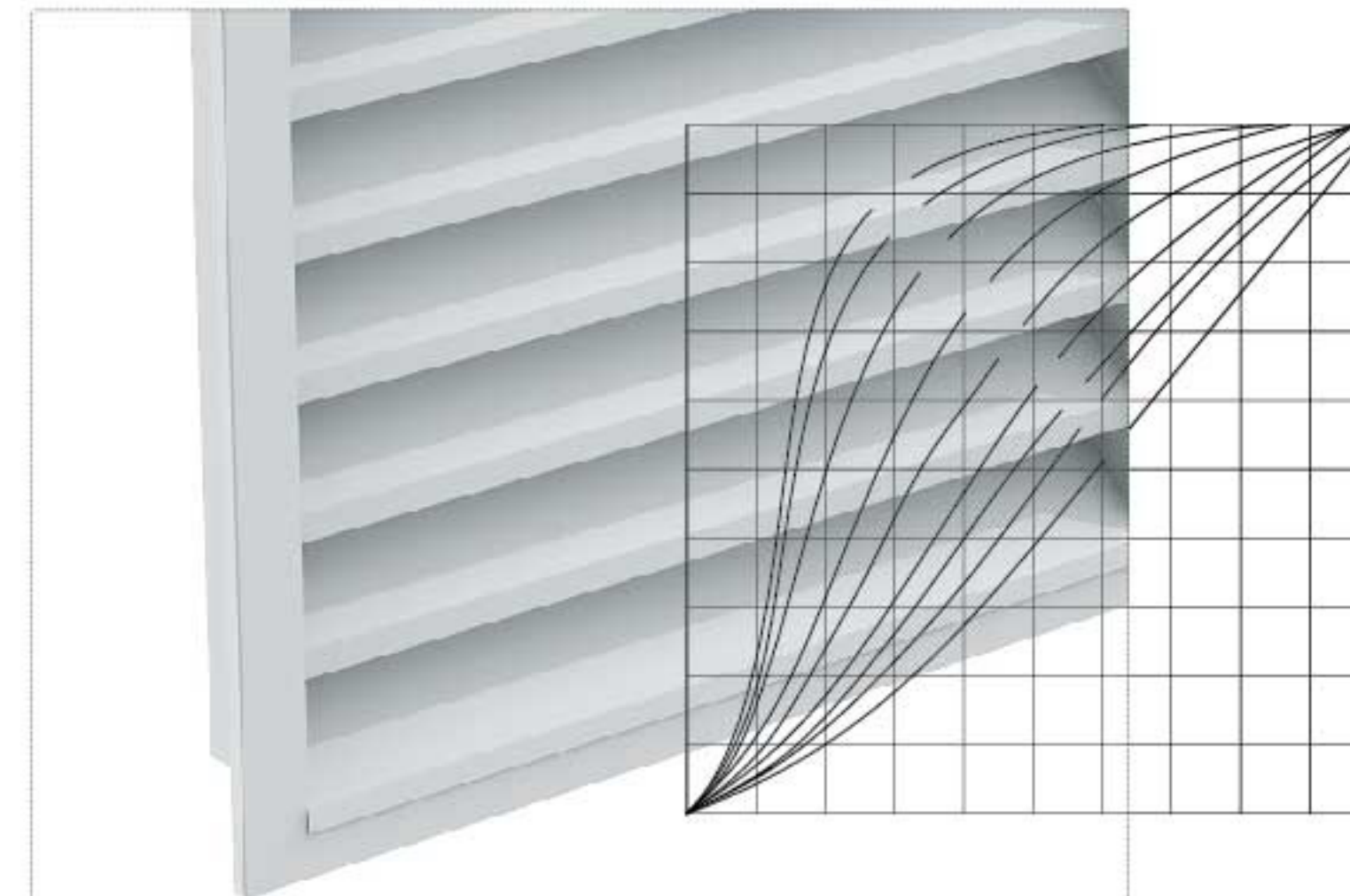
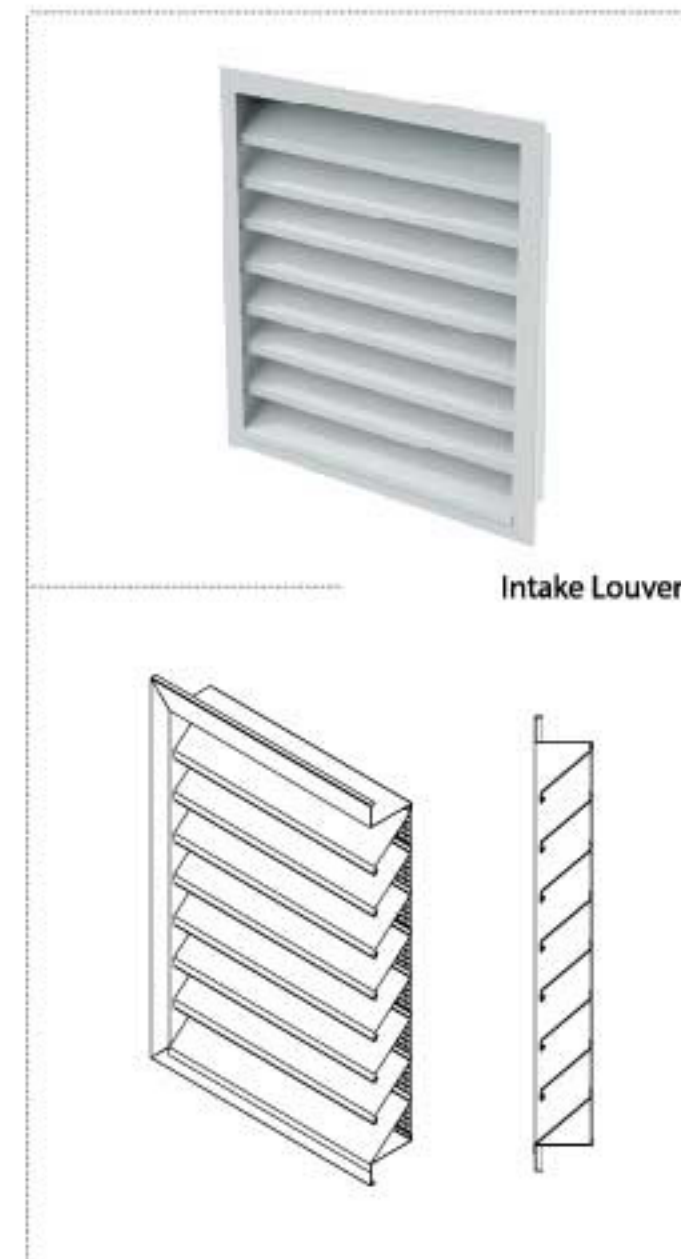
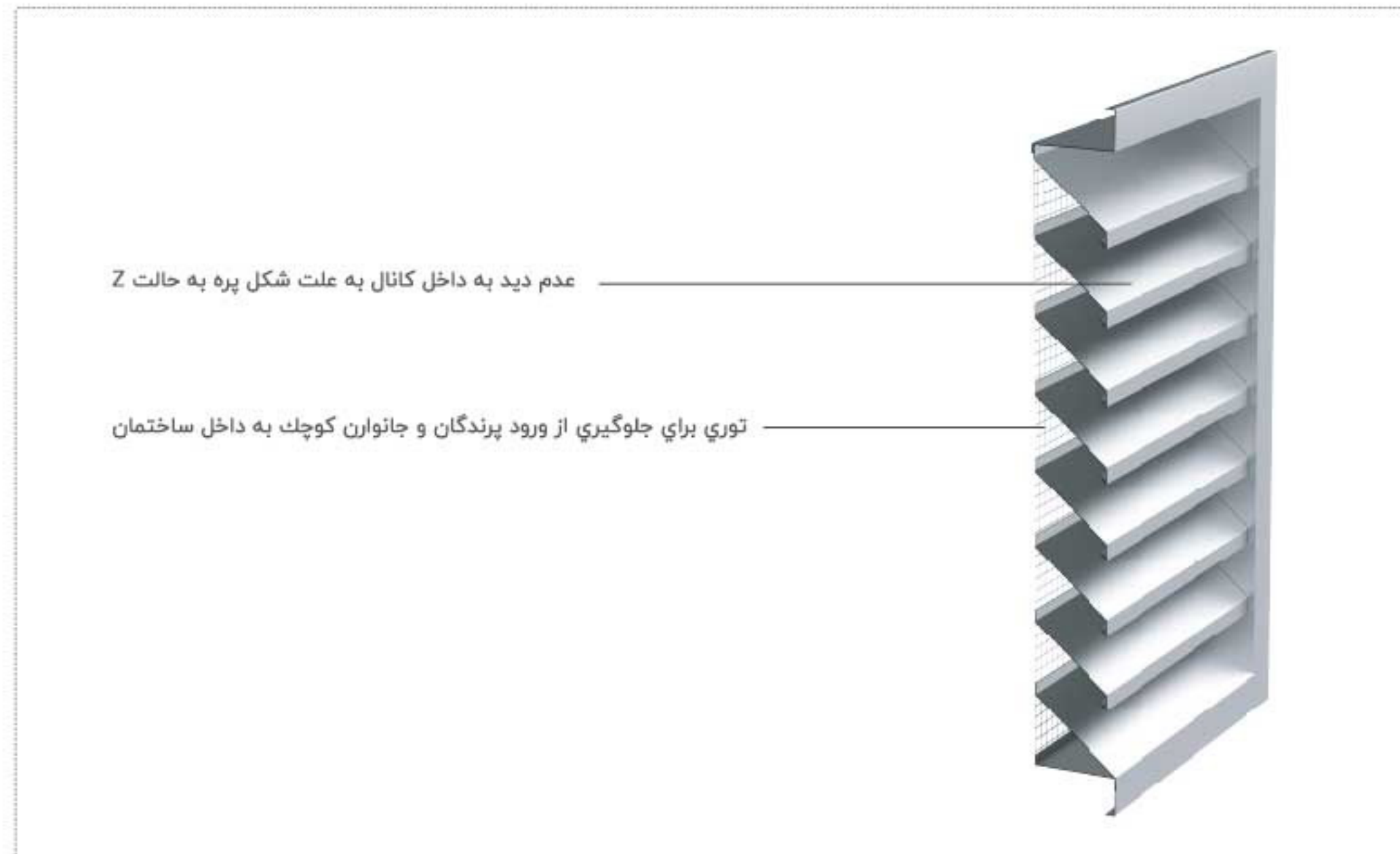

Rooftop Louver

Application

- Can be installed in exhaust ducts and free suction in roof top
- Protection of Fans and intake Louver equipment for exhaust and suction in roof top

Capabilities:

- Prevention rain from entering the Louver and its facilities
- Covered by net fabric to prevent the release of airborne particles
- Low pressure drop and high useful level
- High manufacturing flexibility according to project's conditions and requirement

Intake Louver

Application

- Fresh air entrance for spaces where equipment such as lovers or diesel generators operate.
- Installation on the walls, doors and windows of the building according to the needs of the consumer

Capabilities:

- Made of Aluminum, Iron and Galvanize
- Prevention of penetration of rain, snow and any airborne particles into the buildings.
- Possibility to install protective net fabric
- High strength due to the shape of the blades and high thickness of the sheet

Characteristic Curves of Installed Opposed Blade Dampers

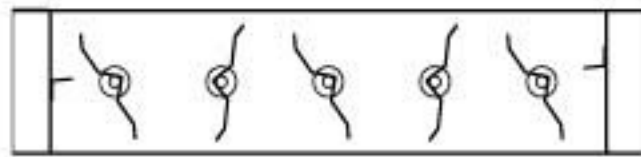
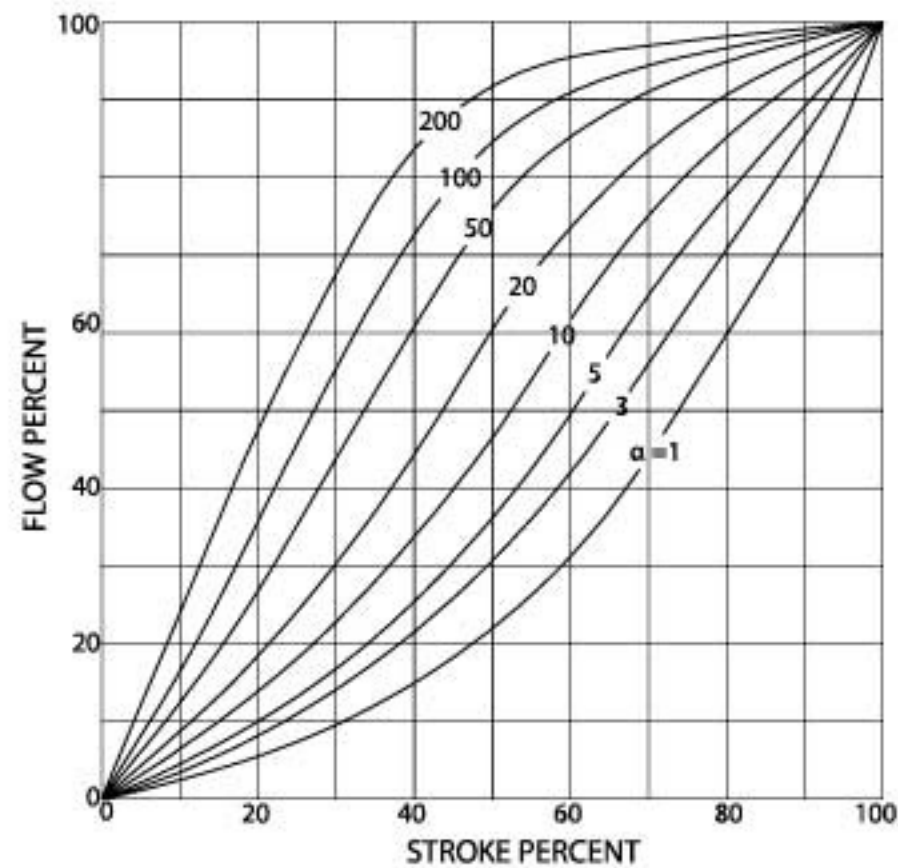

Opposed Operation / پره متقابل

Characteristic Curves of Installed Parallel Blade Dampers

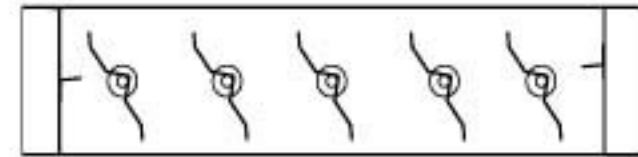
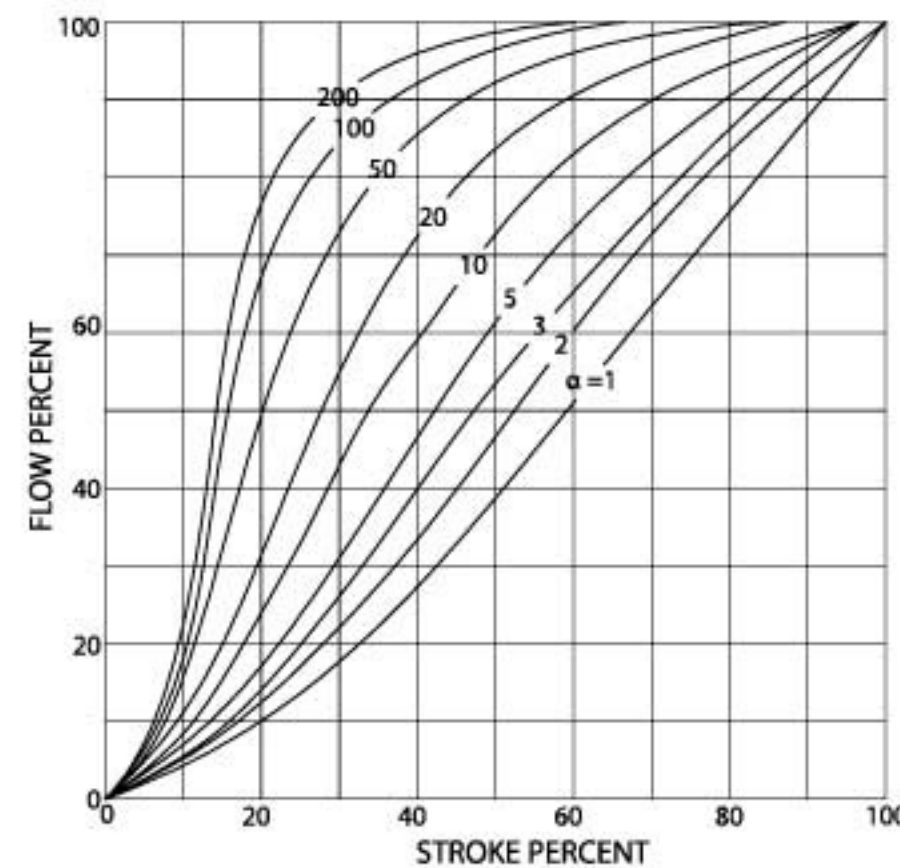

Parallel Operation / پره موازی



Motorized Square Opposed Blade Damper Triple V Shape



Manual Square Opposed Blade Damper Triple V Shape



Volume Control Damper (V shape)

Volume Control Damper is used to control the amount of air passing through the air duct.

This model can adjust or cut off the air flow inside the duct or behind the air vents.

The Volume Control Damper consists of one or more blades inside its structure that are parallel or opposite, and these blades are connected by special levers.

Volume control dampers are designed for regulation of airflow pressure in ventilation ducts in two types of manual and motorized.

Applications:

- Made of Steel Carbon sheet, Galvanized sheet, Aluminum sheet
- Available in two types of manual or motorized gradually by On/Off button
- Available with Parallel or opposed blade

Free cross Sectional Area, A (m²)

H (mm)	B (mm)																			
	200	250	300	350	400	450	500	550	600	650	700	750	800	900	1000	1100	1200	1300	1400	1500
200	0.014	0.019	0.024	0.029	0.034	0.039	0.044	0.049	0.054	0.059	0.064	0.069	0.074	0.084	0.094	0.104	0.114	0.124	0.134	0.144
250	0.021	0.029	0.036	0.044	0.051	0.059	0.066	0.074	0.081	0.089	0.096	0.104	0.111	0.126	0.141	0.156	0.171	0.186	0.201	0.216
300	0.028	0.038	0.048	0.058	0.068	0.078	0.088	0.098	0.108	0.118	0.128	0.138	0.148	0.168	0.188	0.208	0.228	0.248	0.268	0.288
350	0.035	0.048	0.060	0.073	0.085	0.098	0.11	0.123	0.135	0.148	0.16	0.173	0.185	0.21	0.235	0.26	0.285	0.31	0.335	0.36
400	0.042	0.057	0.072	0.087	0.102	0.117	0.132	0.147	0.162	0.177	0.192	0.207	0.222	0.252	0.282	0.312	0.342	0.372	0.402	0.432
450	0.049	0.067	0.084	0.102	0.119	0.137	0.154	0.172	0.189	0.207	0.224	0.242	0.259	0.294	0.329	0.364	0.399	0.434	0.469	0.504
500	0.056	0.076	0.096	0.116	0.136	0.156	0.178	0.196	0.216	0.236	0.256	0.276	0.296	0.336	0.376	0.416	0.456	0.496	0.536	0.576
550			0.108	0.131	0.153	0.178	0.198	0.221	0.243	0.266	0.288	0.311	0.333	0.378	0.423	0.468	0.513	0.558	0.603	0.648
600			0.12	0.145	0.17	0.195	0.22	0.245	0.27	0.295	0.32	0.345	0.37	0.42	0.47	0.52	0.57	0.62	0.67	0.72
650			0.132	0.16	0.187	0.215	0.242	0.27	0.297	0.325	0.352	0.38	0.407	0.462	0.517	0.572	0.627	0.682	0.737	0.792
700			0.144	0.174	0.204	0.234	0.264	0.294	0.324	0.354	0.384	0.414	0.444	0.504	0.564	0.624	0.684	0.744	0.804	0.864
750			0.156	0.189	0.221	0.254	0.286	0.319	0.351	0.384	0.416	0.449	0.481	0.546	0.611	0.676	0.741	0.806	0.871	0.936
800			0.168	0.203	0.238	0.273	0.308	0.343	0.378	0.413	0.448	0.483	0.518	0.588	0.658	0.728	0.798	0.868	0.938	1.008



Manual Round Disc Blade Damper

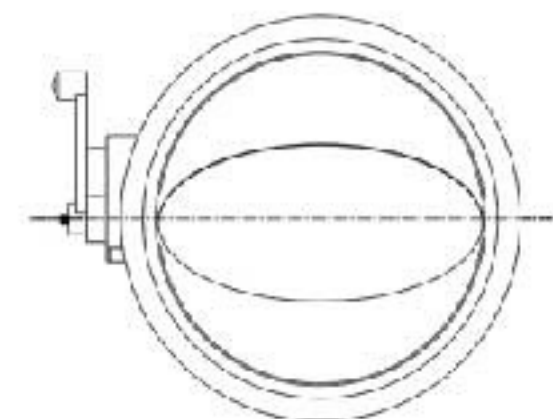

Free cross Sectional Area, A (m²)

H (mm)	B (mm)									
	200	250	300	350	400	450	500	550	600	650
200	0.014	0.019	0.024	0.029	0.034	0.039	0.044	0.049	0.054	0.059
250	0.021	0.029	0.036	0.044	0.051	0.059	0.066	0.074	0.081	0.089
300	0.028	0.038	0.048	0.058	0.068	0.078	0.088	0.098	0.108	0.118
350	0.035	0.048	0.060	0.073	0.085	0.098	0.11	0.123	0.135	0.148
400	0.042	0.057	0.072	0.087	0.102	0.117	0.132	0.147	0.162	0.177
450	0.049	0.067	0.084	0.102	0.119	0.137	0.154	0.172	0.189	0.207
500	0.056	0.076	0.096	0.116	0.136	0.156	0.178	0.196	0.216	0.236
550			0.108	0.131	0.153	0.178	0.198	0.221	0.243	0.266
600			0.12	0.145	0.17	0.195	0.22	0.245	0.27	0.295
650			0.132	0.16	0.187	0.215	0.242	0.27	0.297	0.325
700			0.144	0.174	0.204	0.234	0.264	0.294	0.324	0.354
750			0.156	0.189	0.221	0.254	0.286	0.319	0.351	0.384
800			0.168	0.203	0.238	0.273	0.308	0.343	0.378	0.413

Aerodynamic Selection / Free Cross Sectional area (Table 1)

Free cross Sectional Area, A (m²)

H (mm)	B (mm)									
	700	750	800	900	1000	1100	1200	1300	1400	1500
200	0.064	0.069	0.074	0.084	0.094	0.104	0.114	0.124	0.134	0.144
250	0.096	0.104	0.111	0.126	0.141	0.156	0.171	0.186	0.201	0.216
300	0.128	0.138	0.148	0.168	0.188	0.208	0.228	0.248	0.268	0.288
350	0.16	0.173	0.185	0.21	0.235	0.26	0.285	0.31	0.335	0.36
400	0.192	0.207	0.222	0.252	0.282	0.312	0.342	0.372	0.402	0.432
450	0.224	0.242	0.259	0.294	0.329	0.364	0.399	0.434	0.469	0.504
500	0.256	0.276	0.296	0.336	0.376	0.416	0.456	0.496	0.536	0.576
550	0.288	0.311	0.333	0.378	0.423	0.468	0.513	0.558	0.603	0.648
600	0.32	0.345	0.37	0.42	0.47	0.52	0.57	0.62	0.67	0.72
650	0.352	0.38	0.407	0.462	0.517	0.572	0.627	0.682	0.737	0.792
700	0.384	0.414	0.444	0.504	0.564	0.624	0.684	0.744	0.804	0.864
750	0.416	0.449	0.481	0.546	0.611	0.676	0.741	0.806	0.871	0.936
800	0.448	0.483	0.518	0.588	0.658	0.728	0.798	0.868	0.938	1.008

Aerodynamic Selection / Free Cross Sectional area (Table 2)

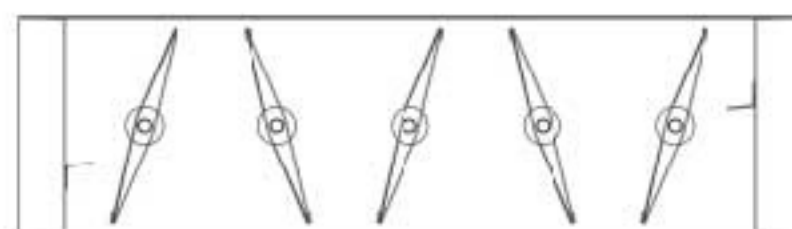

Opposed Operation / پره متقابل

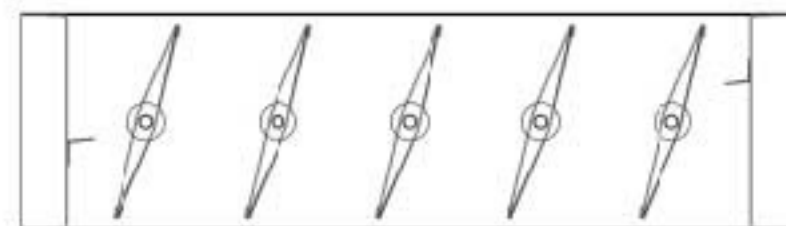

Parallel Operation / پره موازی



Manual Square Parallel Blade Damper Double Skin Shape



Motorized Square Parallel Blade Damper Double Skin Shape

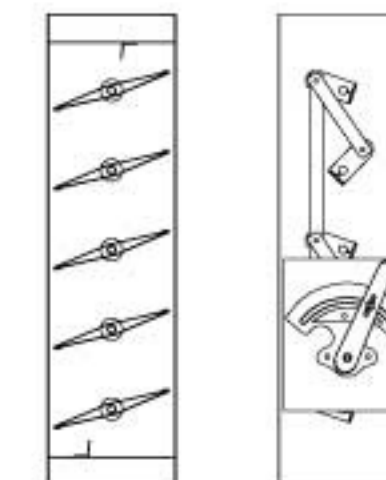
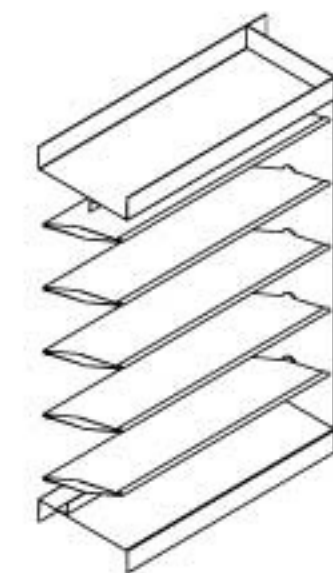

Square Damper Double Skin Shape

The Square Damper Double is used to control the amount of air passing through the air duct. This model can adjust or cut off the air flow inside the duct or behind the air vents.

The Damper Double Skin Shape consists of one or more blades inside its structure that are parallel or opposite, and these blades are connected by special levers.

Volume control dampers are designed for regulation of airflow pressure in ventilation ducts in two types of manual and motorized.

The Damper Double Skin Shape are designed for regulation of airflow pressure in ventilation ducts in two types of manual and motorized.

Applications:

- High Resistance to air flow
- Very low leakage in compared to other types of damper
- Possibility of construction without restrictions in different sizes (for dimensions of length greater than 150 and height greater than 250 cm are made in two pieces.
- Ability to install brass bushings, ball bearings with brass cover and bearings at the blade connection to fit the order
- Compatible with a variety of electrical operators
- Available with thicknesses of sheets from 0.5 mm to 10 mm
- Available with Parallel or opposed blade